

# ***SWIWIN SW600PRO ENGINE TECHNICAL MANUAL***



***you and us***

***welcome to the age of turbojet models! swiwin is ready to take you to experience different flight fun!***

***firstly, please carefully read this manual to have a comprehensive understanding and impression of the engine, engine components, and operating process, in order to ensure the safe operation and optimal performance of the engine.***

***this manual will introduce you to how to install, operate, and maintain the engine. if you still have any questions, please feel free to contact us. we will wholeheartedly provide you with sales, technical, and after-sales support services for the swiwin sw600pro engine. this instruction manual aims to provide users with detailed usage guidelines and recommendations to ensure the safety of the engine operation and optimal performance.***

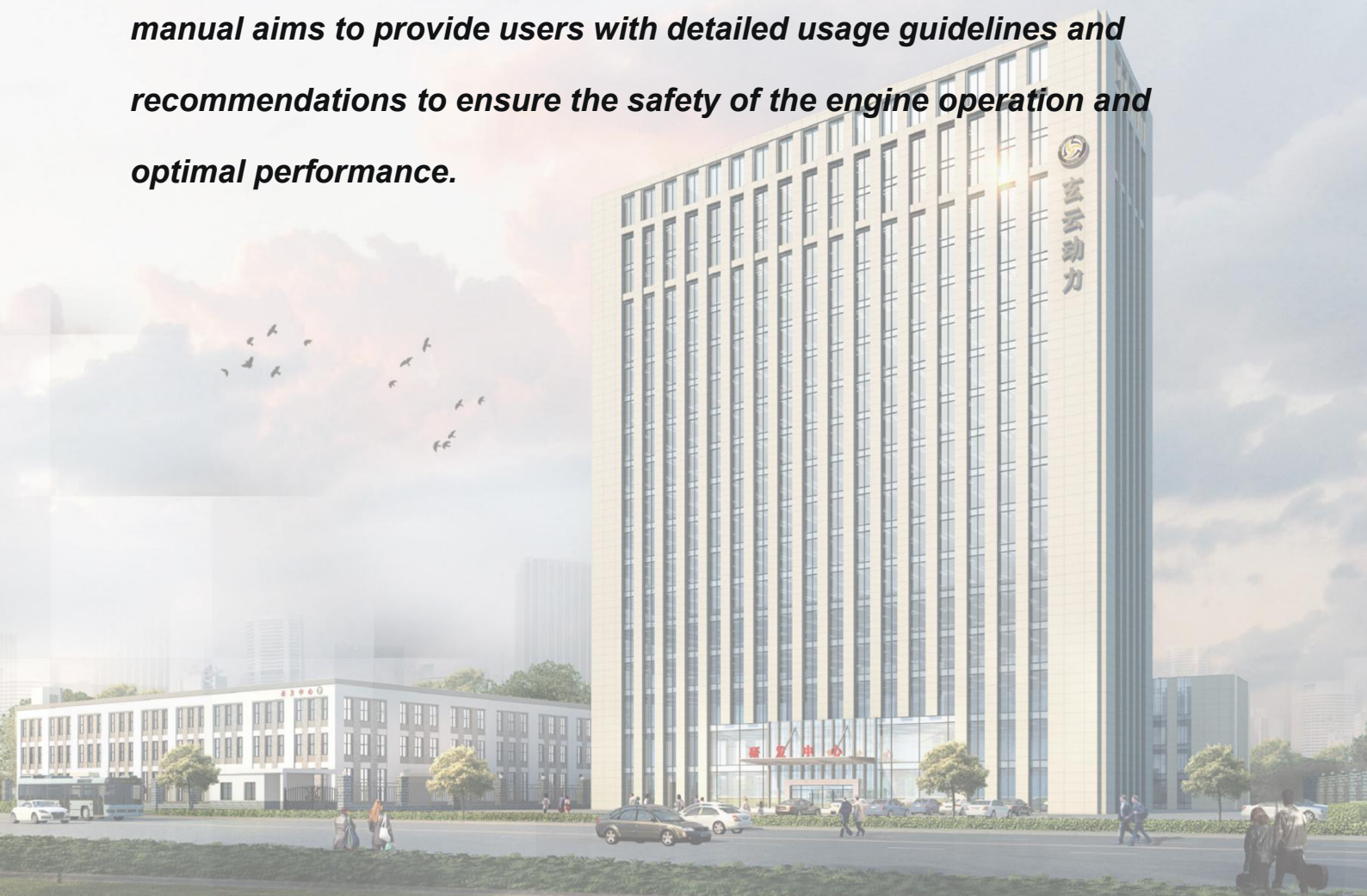

## CATALOGUE

<b>1. ENGINE INTRODUCTION.....</b>	<b>3</b>
<b>2.PRODUCT SPECIFICATIONS.....</b>	<b>4</b>
2.1 DIMENSIONAL DRAWING.....	4
2.2 BASIC PARAMETERS OF ENGINE.....	5
2.3 PARAMETERS OF ENGINE OPERATION CONTROL.....	5
<b>3. SAFETY INSTRUCTIONS.....</b>	<b>7</b>
<b>4. INSTALLATION AND DEBUGGING.....</b>	<b>9</b>
<b>5. ENGINE USAGE INSTRUCTIONS.....</b>	<b>9</b>
5.1 LIST OF ENGINE ACCESSORIES.....	9
5.2 ENGINE CONNECTION.....	10
5.3 SW600PRO ELECTRICAL CONNECTION METHOD.....	10
5.4 DEFINITION OF EXTERNAL SIGNAL CONNECTION PLUG.....	11
5.5 ABOUT CONTROL PROTOCOL.....	12
5.6 ENGINE CONNECTION INSTRUCTIONS FOR DIFFERENT STARTING MODES.....	13
5.7 GSU USER MANUAL.....	13
5.8 ECU (V5) USAGE INSTRUCTIONS.....	23
<b>6. ENGINE DEBUGGING.....</b>	<b>36</b>
6.1 SETTING OPERATION MODE.....	36
6.2 CHECKLIST.....	36

6.3ENGINE START AND STOP.....	37
6.4 PC CONTROL START AND STOP.....	37
<b>7. ENGINE OPERATING STATUS DESCRIPTION.....</b>	<b>37</b>
<b>8. FREQUENTLY ASKED QUESTIONS AND ANSWERS.....</b>	<b>39</b>
8.1 COMMON PROBLEM ELIMINATION.....	39
8.2 ANALYSIS OF ECU ERROR FAULTS.....	39
<b>9. COMPATIBILITY.....</b>	<b>41</b>
9.1 COMPATIBILITY OF SERIAL PORT ADAPTER CABLE CONNECTORS.....	41
9.2 UPGRADER COMPATIBILITY.....	42
<b>10. STORAGE AND LUBRICATION.....</b>	<b>42</b>
<b>11. ENGINE MAINTENANCE AND UPKEEP.....</b>	<b>42</b>
<b>12. AFTER SALES SERVICE.....</b>	<b>43</b>

## 1. ENGINE INTRODUCTION

*the sw600pro engine has a high degree of overall design integration, easy installation, and convenient operation. the engine consists of two main parts: the main body and an external ecu controller.*

electronic components integrated within the engine body:

- brushless starter motor
- ignition head
- temperature sensor

**Engine**



components integrated within the ecu controller:

- oil control valve body assembly
- ecu board

**Ecu**



## 2.PRODUCT SPECIFICATIONS

### 2.1 DIMENSIONAL DRAWING

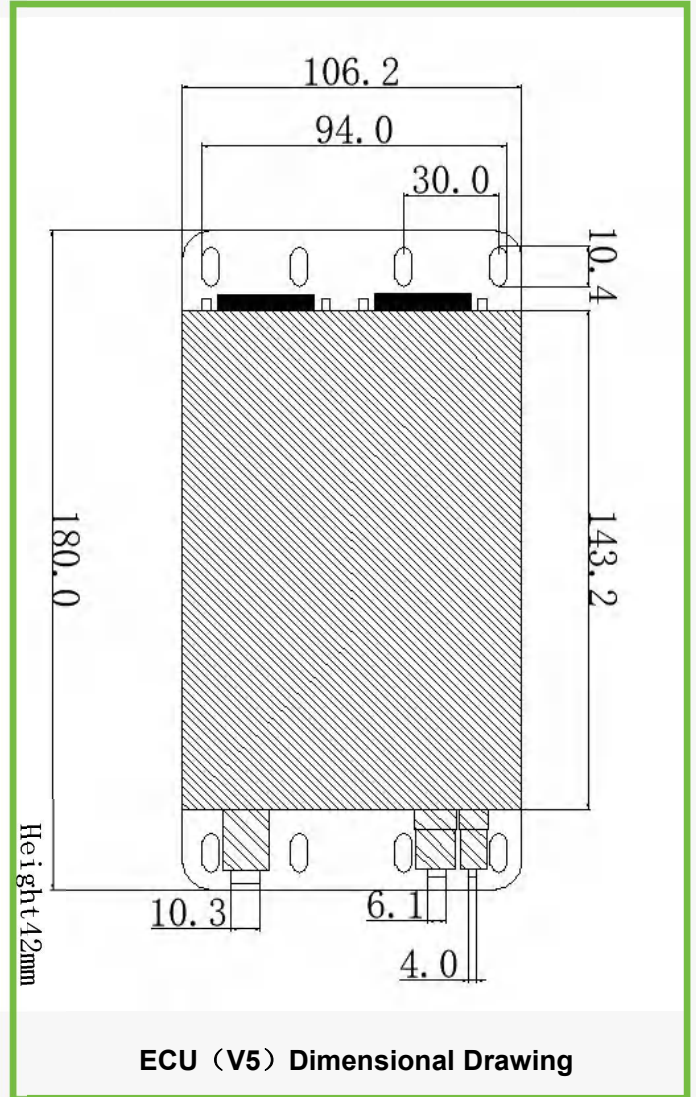
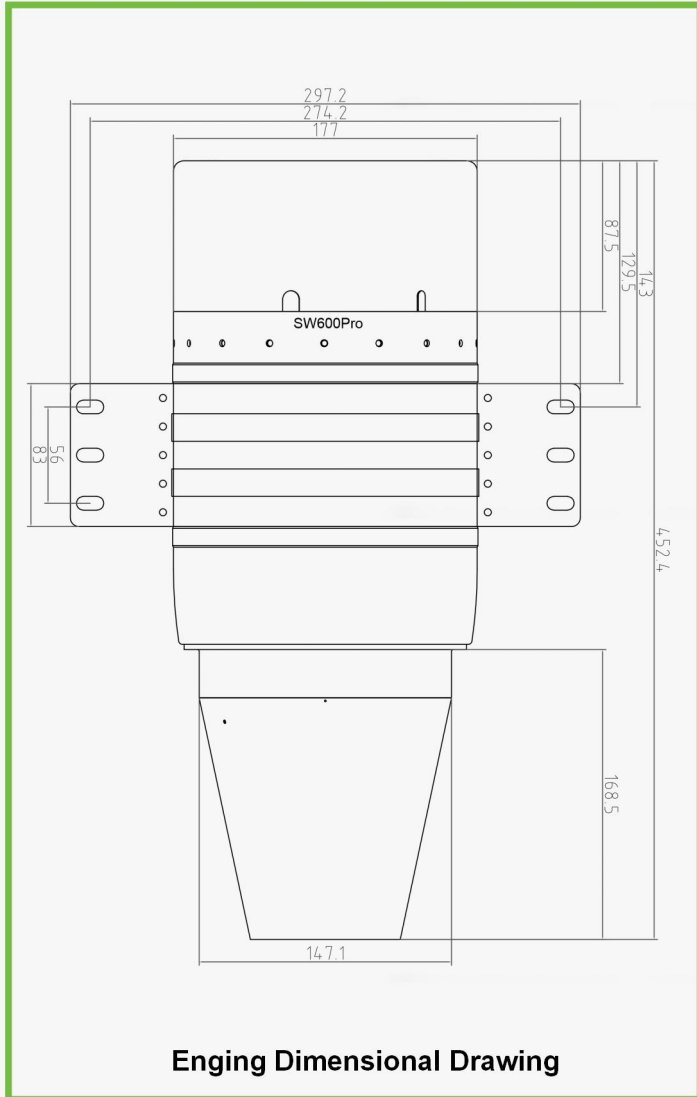

**note:**

- 1. the total design length of the sw600pro engine is 452.4mm, and the length of the tailpipe can be customized according to customer needs.**
- 2. the maximum diameter of the sw600pro engine design is 177mm, which does not include the thickness of the engine fixing clamp. the engine fixing clamp can be customized according to specific customer requirements.**
- 3.the total design weight of the sw600pro engine body is approximately 6800g, and the total weight of the ecu is approximately 910g.**

## 2.2 BASIC PARAMETERS OF ENGINE

PROJECT	PARAMETER
model	SW600Pro
thrust	60kg
diameter (mm)	177mm
length (mm)	452mm
weight	6800g
ecu weight	910g
usage temperature	-40℃~50℃
max usable height	12000m
maxi longitudinal overload during catapult takeoff	20g
max allowable flight speed	300m/s
supply voltage	18V-32V
starting system	one key electronic start
rpm range	25,000-72,000
exhaust temperature	750℃
fuel consumption	1735g/min
fuel	aviation kerosene
lube oil	3%-5%
maintenance Interval	every 25 hours

## 2.3 PARAMETERS OF ENGINE OPERATION CONTROL

PROJECT	PARAMETER
---------	-----------

pump voltage	0.8-1.8V
rpm start up ramp	100%
pump start up ramp	5
glow plug	6.6V
valve	40
ignition rpm	1,300 rpm
preheat rpm	2,000 rpm
rpm off starter	13,000 rpm
rpm acc	10
rpm dec	10
max rpm	72,000 rpm
idle rpm	25,000 rpm
minimum speed	15,000 rpm
max temp	1000℃
low volt	10.0V
restart	close
restart glow plug	same voltage as the ignition head
pump limit	25V
idle stable	5-8
pop-up time	0.5S
ejection voltage	5V
run voltage	4.5V
rpm stable	50
cool	3,000 rpm

**note: all the data were measured under the standard air pressure**



### 3. SAFETY INSTRUCTIONS

*safety notice:*

*thank you for using the swiwin micro turbojet engine. the working state of the turbojet engine is essentially highly extreme mechanical work, which poses a certain degree of danger. the operator must be familiar with the operating points and recognize the risks before use. careless operation can easily cause damage to the turbojet body and personal injury. please carefully read the operating instructions in the manual and strictly follow the operating regulations. if this is your first time operating a turbojet engine, please learn how to operate it under the guidance of experienced personnel. before starting the turbojet engine for the first time, please carefully read this manual.*

*safe distance:*

*the engine operates at extremely high rotational speeds. when the engine is running, it must maintain a safe distance from the aircraft, with a distance of 5 meters in front of the engine and 40 meters on both sides.*

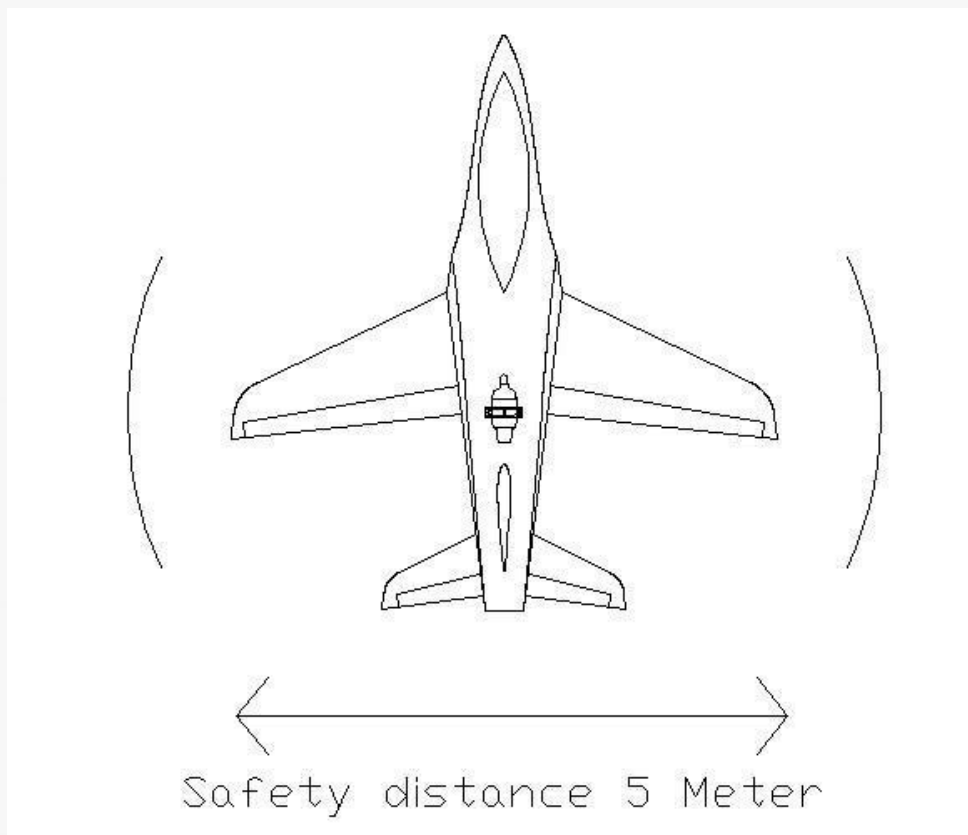

the following diagram shows the hazardous areas during engine operation:

- confirm that no personnel have entered the hazardous area during operation.
- when operating the engine, safety goggles and earplugs must be worn.
- ensure that there are no debris that may be inhaled in the intake area.
- keep your fingers away from the intake area when operating the engine.
- prepare fire extinguishing equipment before operating the engine.

### DANGEROUS AREAS DURING ENGINE START- UP AND IDLE

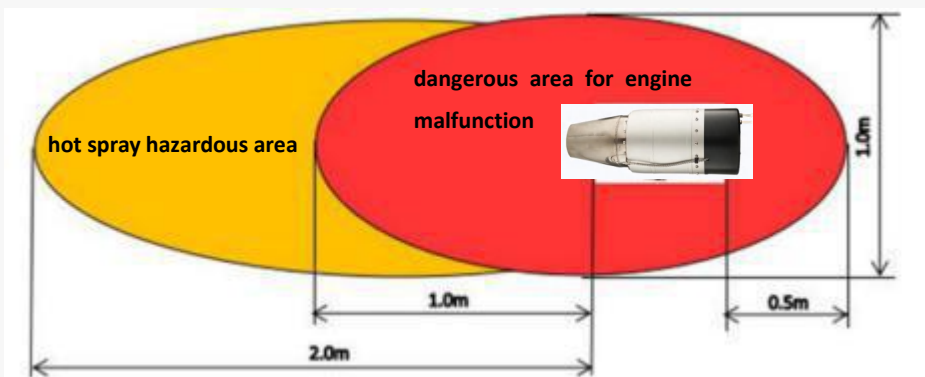

### ENGINE 20% THROTTLE TO FULL THRUST DANGER ZONE

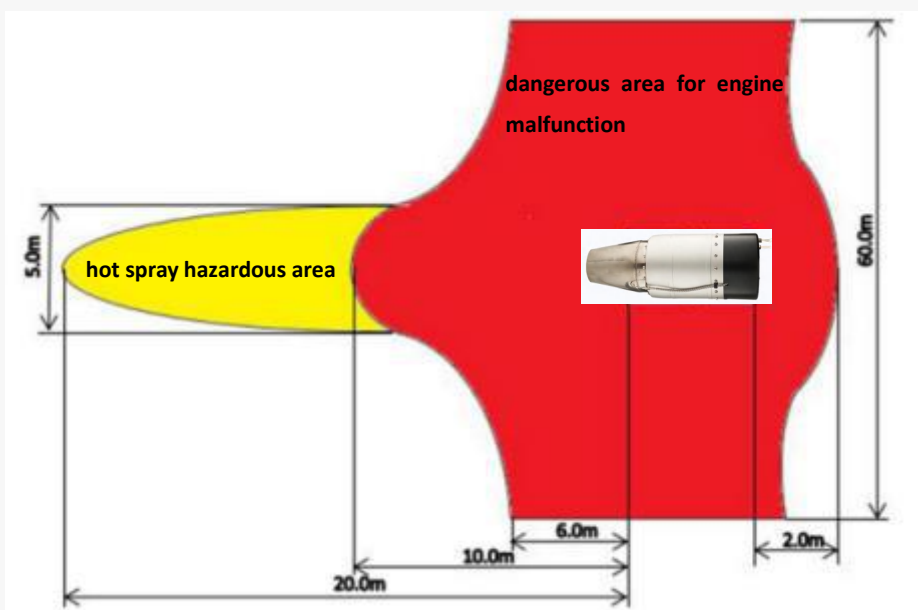

## 4. INSTALLATION AND DEBUGGING

*the sw600pro engine is equipped with a dedicated fixing clamp. before operating the engine, please make sure that the clamp is securely fastened and clamped in the groove of the casing. be careful not to overtighten the fixing screws to prevent deformation of the engine casing and affect the fixing effect. the schematic diagram is as follows.*

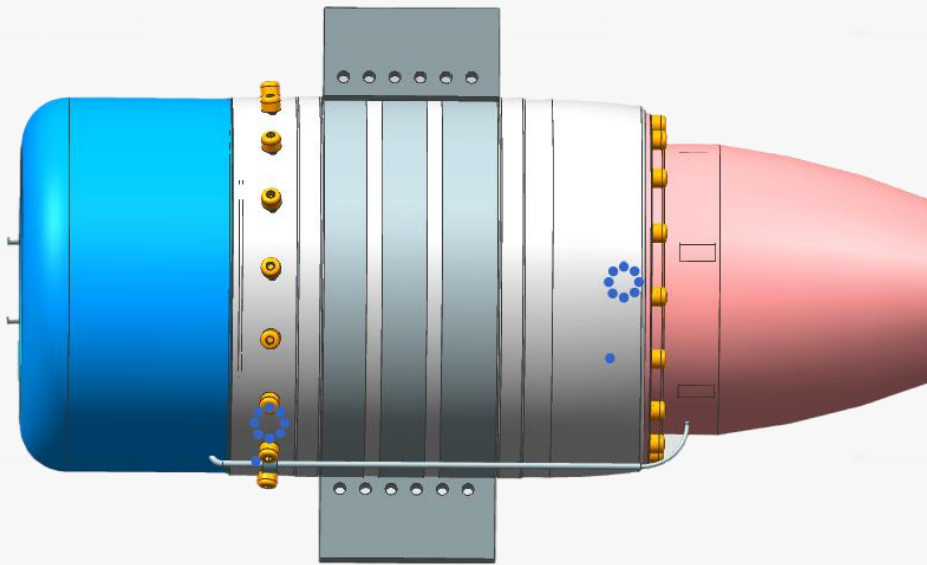







## 5. ENGINE USAGE INSTRUCTIONS

### 5.1 LIST OF ENGINE ACCESSORIES

open the package, the list of engine accessories is as follows



		
<p><b>Fixed bracket</b></p>	<p><b>Upgrade Tool (One to Two)</b></p>	<p><b>Connector</b></p>
		
<p><b>Power Connection Plug</b></p>	<p><b>Signal Connection Plug</b></p>	<p><b>Tubing</b></p>

## 5.2 ENGINE CONNECTION

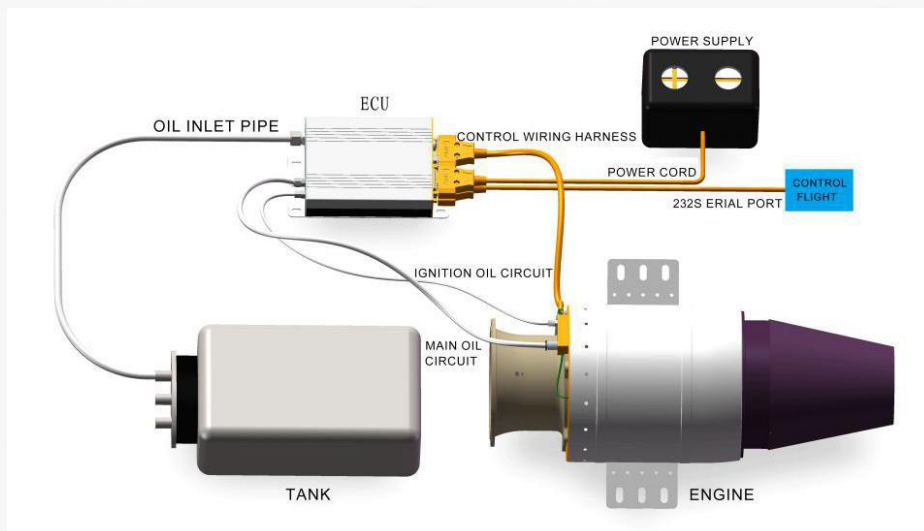

## 5.3 SW600PRO ELECTRICAL CONNECTION METHOD

*the engine data connection is completed through ecu (v5), which has three electrical connection sockets on the side, namely db15 (male) plug, db15 (female) plug, and db3 (male) plug.*

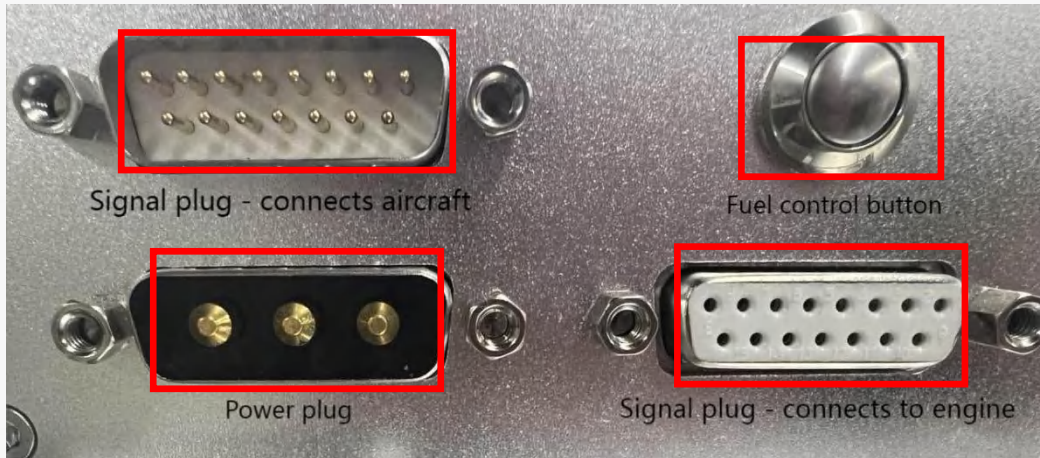

#### 5.4 DEFINITION OF EXTERNAL SIGNAL CONNECTION PLUG

the sw600pro engine signal line plug adopts ws16j7 tq aviation plug, and the plug definition is as follows:

##### RS232 DEFINITION OF SIGNAL LINE WIRING

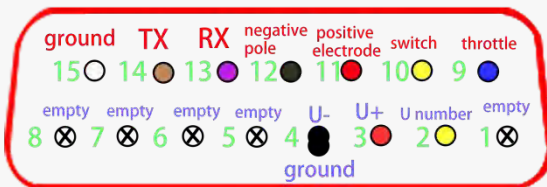

- 2: GSU data
- 3: GSU power supply positive
- 4: GSU negative power supply ground
- 9: PPM throttle
- 10: PPM switch
- 11: PPM power supply positive
- 12: PPM negative power supply
- 13: RX
- 14: TX
- 15: ground

##### RS422 DEFINITION OF SIGNAL LINE WIRING

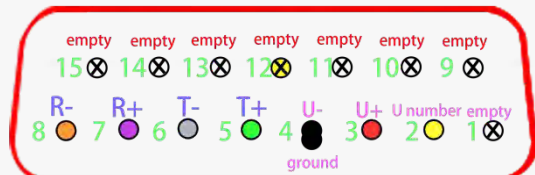

- 2: GSU data
- 3: GSU power supply positive
- 4: GSU negative power supply ground wire
- 5: T+
- 6: T-
- 7: R+
- 8: R-

## 5.5 ABOUT CONTROL PROTOCOL

### 1. throttle signal

*if the customer has no special requirements, the default communication protocol at the factory is "zk", with a baud rate of 9600, rs232 serial port, stop bit 1, and no checksum. the throttle adopts a pulse width (pwm) control method, with a pulse width of 1ms~2ms. 1ms corresponds to the minimum throttle (0%), 2ms corresponds to the maximum throttle (100%), and the pulse high level is 3.3v and 5v (3.3v and 5v are available on average), while the pulse low level is 0v.*

### 2. start switch

*the startup switch adopts a pulse width (pwm) control method, with a pulse width of 1ms~2ms. 1ms corresponds to off and 2ms corresponds to on. the pulse high level is 3.3v and 5v (3.3v and 5v are available on average), and the pulse low level is 0v.*

### 3. telemetry data

①*the engine has telemetry function and transmits data through a 232 standard serial port with a baud rate ranging from 9600bps to 57600bps.*

②*the data to be measured includes but is not limited to engine speed, engine throttle, fuel pump voltage, engine status, and error messages.*

③*to test the communication protocol openness of the data, provide detailed communication protocol documentation.*

### 4. data recording

①*the engine has a data recording function, which can record data from 2 hours before the engine failure.*

②*the data recording content includes but is not limited to engine speed, engine throttle, oil pump voltage, engine status, and error messages.*

③*provide engine data analysis software for post flight data analysis.*

④*customization is supported within the scope of the engine control protocol.*

## 5.6 ENGINE CONNECTION INSTRUCTIONS FOR DIFFERENT STARTING MODES

*Instructions for connecting and starting the engine controlled by the re232 serial port tool*

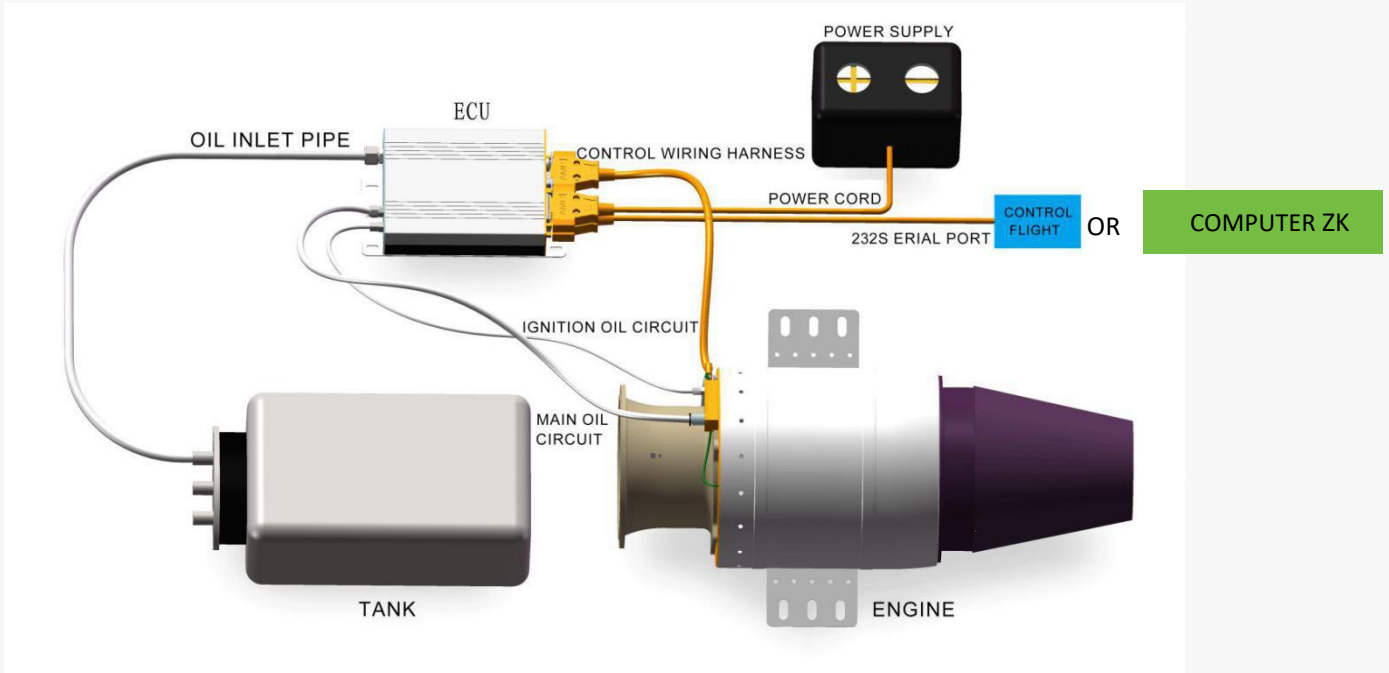

## 5.7 GSU USER MANUAL

### INITIAL INTERFACE OF GSU AFTER CONNECTING THE ENGINE

*when the engine is not started, the gsu displays rpm, temp, etc. after the engine is started, the data displayed by the gsu is real-time measured data.*

GSU SCREEN DISPLAY:

RPM:

TEMP:

CURRY:

PRE:

PWRVOL:

PEVOL: ENGINE MODEL

TIME: ACC:

STATE:

COLUMN CHART (RPM,TEMP,PUMP,RC)



note:

- ① acc represents the acceleration time from idle to 100% maximum speed, measured in seconds;
- ② the oil pump value is the output voltage multiplied by 1000. for example, if the maximum speed output is 4.0v, it will display 4000;
- ③ the temperature unit can be switched between celsius or fahrenheit and has calibration function;

## ECU SETTING INTERFACE

press the ok button to enter the settings directory. the data in the upper part of the display screen is the last run record, and the settings interface is below. it is divided into nine parts: engine start-up, engine operation, remote calibration, starter motor, engine cooling, other settings, test settings, data charts, language settings, etc. press the "+" and "-" buttons to manually select from nine options.

GSU SCREEN ISPLAY:

RUN INFORMATION

TOTAL TIME:

CYCLE:

STOPRPM:

STOPTEMP:

MAXRPM:

SETTING

STARTUP, RUNNING, STUDY RC,

STARTER, COOLING, OTHER, TEST,

DATA CHART, LANGUAGE

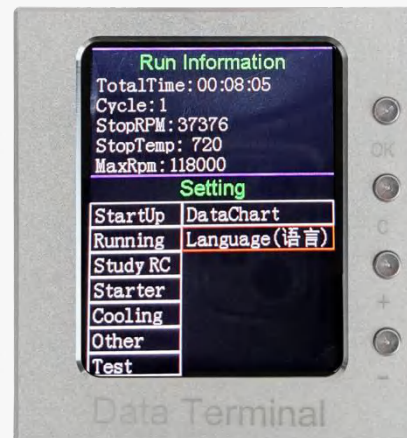

## ENGINE STARTUP SETTINGS

when the engine startup option is selected, press the ok key to enter the startup parameter setting interface. press the plus sign "+" and minus sign "-" to select various parameter options, press the ok key to select the option, and then press the plus sign



"+" and minus sign "-" to set the size and value of the parameters. the meaning represented by each parameter is as follows:

- *pump voltage: the driving voltage of the oil pump during ignition. if the oil pump cannot rotate smoothly or waits for too long to rotate during each ignition, increase this value. control the oil output during startup, the higher the voltage, the more oil is supplied during startup.*
- *rpm startup ramp: refers to the slope of the increase in starting motor speed during the period from ignition to clutch disengagement. the higher the slope, the faster the speed increase.*
- *pump startup ramp : adjust the fuel supply slope between clutch disengagement and idle speed; it refers to the fuel supply slope of the oil pump during the engine start-up phase. the higher the slope value, the greater the fuel supply.*
- *glow plug: the voltage value supplied to the ignition head during engine ignition generally does not exceed 7v. when the weather is cold or the ignition only emits smoke without igniting, it is because the temperature of the ignition head is not high enough. you can try to slightly adjust it by 0.2v each time, and the maximum cannot exceed 7v. adjusting it arbitrarily can easily cause overheating and shorten the life of the ignition head;*
- *valve: when the engine is ignited, it controls the amount of oil in the ignition oil circuit. the higher the oil threshold, the longer the opening time, and the more fuel is supplied.*
- *ignition RPM: when the ignition speed is reached, the engine starts to ignite, the hot head lights up, and the ignition program enters.*
- *prehea rpm: when the engine reaches the preheating temperature, the engine speed increases to the preheating speed and enters the preheating program.*
- *rpm off starter: when the specified disengagement speed is reached, the starter motor clutch will disengage from the spindle clutch. speed: when the specified disengagement speed is reached, the starter motor clutch will disengage from the spindle.*

GSU SCREEN PUMP  
 VOLTAGE:  
 START-UP  
 RPM VOLTAGE:  
 RPM STARTUP RAMP:  
 PUMP STARTUP RAMP  
 GLOW PLUG  
 VALVE  
 IGNITON RMP  
 PRECHEA TRPM  
 RPM OFF STAETER  
 OTHER  
 TEST

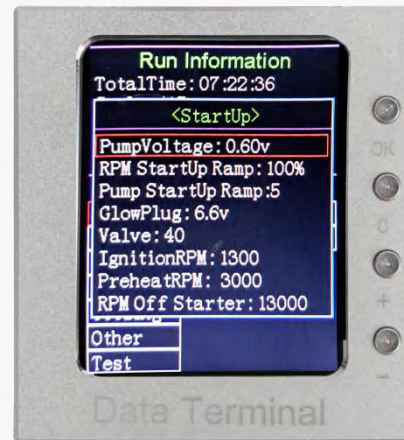

## ENGINE OPERATING PARAMETER SETTING INTERFACE::

*press the c key from the previous interface to exit and enter the settings directory interface. press the plus "+" and minus "-" keys to select the engine running and enter the engine running parameter setting interface below. press the plus sign "+" and minus sign "-" to select various parameter options, press the ok key to select the option, and then press the plus sign "+" and minus sign "-" to set the size and value of the parameters. the meaning represented by each parameter is as follows:*

- *rpm acc: the higher the acceleration value, the faster the fuel supply slope and the faster the acceleration time.*
- *rpm dec: the higher the deceleration value, the faster the oil collection slope and the faster the oil collection time.*
- *max rpm: the maximum rpm value reached by the engine setting.*
- *idle rpm: the standby speed value set by the engine.*
- *min rpm: below the minimum speed, the ecu defaults to engine shutdown.*
- *max temp: temperature protection value. when the temperature exceeds the maximum temperature, flameout protection will be implemented.*

➤ low colt: when the voltage falls below the minimum value, the engine will issue a low voltage alarm.

➤ restart glow plug: the ignition voltage during automatic startup.

➤ puml imit: after reaching the specified limit value, the oil pump value will not increase.



## REMOTE CONTROL OPERATION CALIBRATION LEARNING INTERFACE

press the c key from the previous interface to exit and enter the settings directory interface. press the plus "+" and minus "-" keys to select the calibration remote control and enter the remote control operation calibration learning parameter setting interface below. press the plus sign "+" and minus sign "-" to select various parameter options, press the ok key to select the option, and then press the plus sign "+" and minus sign "-" to set the size and value of the parameters. the meaning represented by each parameter is as follows.

➤ set the throttle stroke from this menu, and futaba's remote control must set the throttle channel to reverse phase;

➤ max: indicates the highest throttle, maximum throttle, highest fine adjustment

➤ idle: indicates idle throttle, minimum throttle, maximum fine adjustment

➤ failsatettime: indicates turning off the accelerator, minimum throttle, and minimum fine adjustment

- *protocol: The factory setting is ZK. If you have any special requirements, please contact swiwin after-sales personnel*
- *uart-band rate: The factory setting is 9600, which can be adjusted according to customer requirements*
- *uart-stop bit: The factory setting is 2, which can be adjusted according to customer requirements*

GSU THE SCREEN WILL DISPLAY:

RC STUDY

MAX:

IDLE:

FAILSATETIME:

PROTOCOL:

UART-BAND

RATE:

UART-STOP BIT:



**STARTING MOTOR PARAMETER SETTING INTERFACE:**

- *eject time: control the time for the starter motor to pop up the clutch*
- *eject voltage: the voltage value when the clutch is disengaged.*
- *run voltage: the voltage value at which the motor operates normally during the start-up phase.*
- *rpm stable: when starting, the speed will not have a significant up and down fluctuation stabilizing effect.*

GSU THE SCREEN WILL DISPLAY:

START

EJECT TIME:

EJECT VOLTAGE:

RUN VOLTAGE:

RPM STABLE:



## ENGINE COOLING PARAMETER SETTING INTERFACE:

press the c key to exit from the previous interface and enter the settings directory interface. press the plus "+" and minus "-" keys to select engine cooling and enter the engine cooling parameter settings interface below.

rpm: after the engine is turned off normally, the starter motor will run to cool the engine until it reaches room temperature. the rotational speed refers to the operating speed of the starting motor during cooling.

GSU THE SCREEN WILL DISPLAY:

RPM:



## REMARKS:

① set the cooling speed after normal shutdown, and stop cooling when the engine automatically cools down to 80 °C after normal shutdown. cooling is the continuous operation of the starter motor, as the ecu cannot determine whether there is a fire condition in case of accidental shutdown. therefore, if the shutdown is not normal, it will not automatically cool down;

② when the engine unexpectedly stalls, it is also necessary to cool down as quickly as possible to protect the engine. at this time, manual cooling can be used by placing the fine adjustment at the lowest position and pushing the throttle to the highest position to perform manual cooling;

③ if the temperature is above 80 °C during startup, it will also be cooled first until the temperature drops below 80 °C before starting;

## OTHER PARAMETER SETTING INTERFACE:

press the c key to exit from the previous interface and enter the settings directory interface. press the plus sign "+" and minus sign "-" keys to select other parameters and enter the other parameter settings interface below. press the plus sign "+" and minus sign "-" to select various parameter options, press the ok key to select the option, and then press the plus sign "+" and minus sign "-" to set the size and value of the parameters.

the meaning represented by each parameter is as follows:

*battery reset: after the test is completed, reset all the battery used in the ecu to zero (for recording purposes)*

*adjust temperature: adjust according to the environment.*

*oil pump type: adjust according to the oil pump used.*

*software version: latest*

GSU THE SCREEN WILL DISPLAY:

CLEARBATUSED:

ADJUSTTEMP:

TEMPERATURE UNIT:

TEMPTYPE:

ECU-VER VERSION:

GSU - VER:



## TEST PARAMETER SETTING INTERFACE:

press the c key to exit from the previous interface, enter the settings directory interface, select the test by pressing the plus "+" and minus "-" keys, and enter the test parameter settings interface below. press the plus sign "+" and minus sign "-" to select from various parameter options, and press the ok key to select the option. the testing function is to test whether certain hardware can work properly.

GSU THE SCREEN WILL DISPLAY:

- TEST ENGINE
- TEST FUEL PUMP
- TEST IGNITI PUMP
- TEST FUEL VALUE
- TEST GAS VALUE
- TEST GLOWPLUG
- TEST STARTER

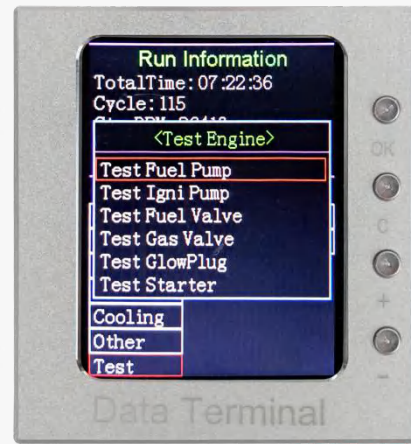

#### DATA CHART DISPLAY INTERFACE:

*data chart: record the status of engine start-up and operation. different colored curves represent different meanings. green represents speed, red represents temperature, light blue represents oil pump, and blue represents voltage.*

- GSU THE SCREEN WILL DISPLAY:
- DATA CHART (CURVE CHART AREA)
  - RPM (GREEN TEXT):
  - TEMPE(RED TEXT):
  - PUMP (LIGHT BLUE):
  - COOLING (WHITE TEXT):
  - PWRVOL (DARK BLUE TEXT):
  - RC (YELLOW TEXT):

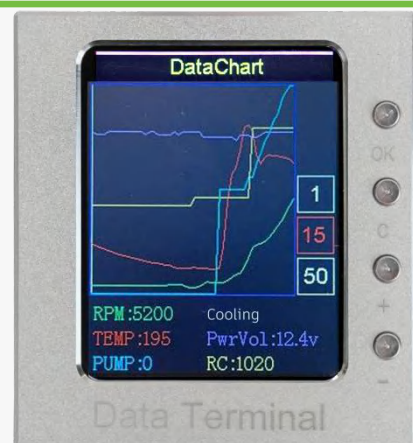

#### SET LANGUAGE INTERFACE:

*by selecting, the monitor can be set to different languages such as english, simplified chinese, traditional chinese, and spanish.*

GSU THE SCREEN WILL  
DISPLAY:  
SET LANGUAGE  
ENGLISH  
中文（简体）  
中文（繁体）  
SPANISH  
RESET CONFIG

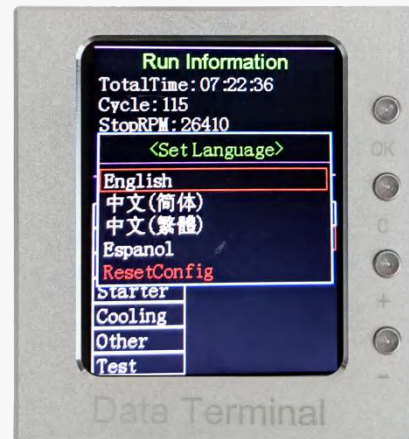

## TEMPERATURE CALIBRATION

*during the engine start-up process, the ecu controls the engine operation by judging the built-in temperature sensor. if the temperature sensor inside the engine differs significantly from the ambient temperature, it will affect the ecu's judgment and require the use of gsu for temperature calibration of the engine.*

on the gsu main interface, select  
"other"

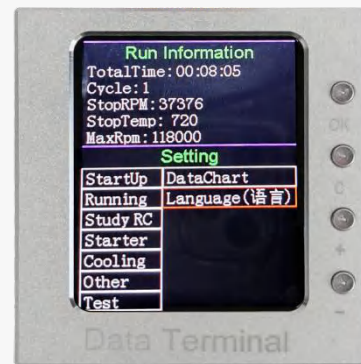

select 'adjust temp' and click '+-' to  
adjust the temperature up and down,  
keeping the corrected temperature  
consistent with the ambient  
temperature.





## 5.8 ECU (V5) USAGE INSTRUCTIONS

*hardware preparation: the following hardware is required for downloading or changing settings and parameters of ecu (v5) data*

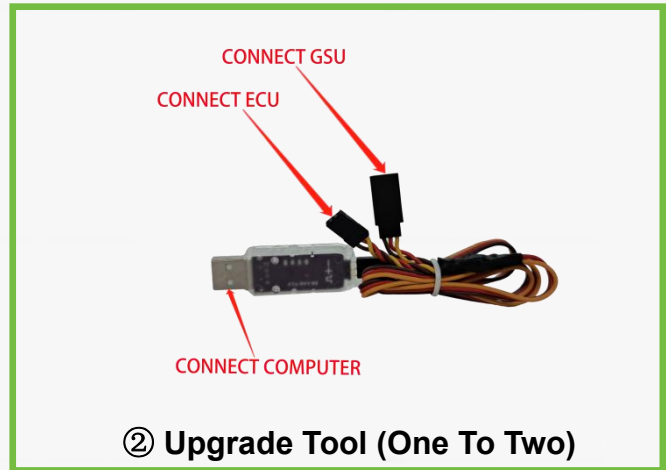

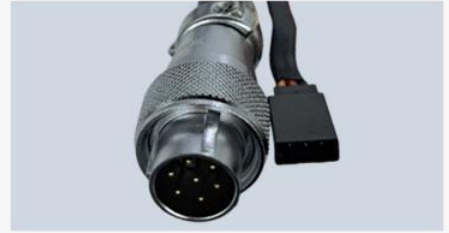

⑤ **Signal Line**

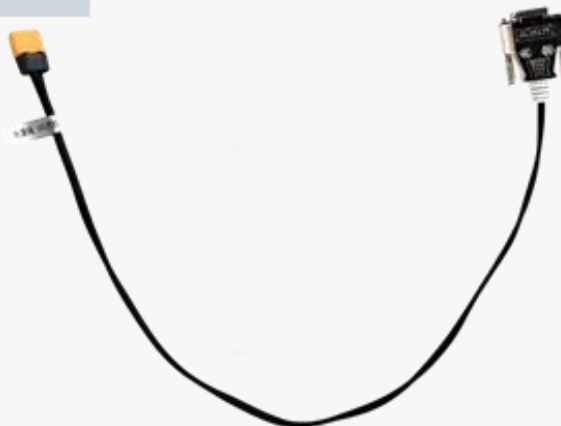

⑥ **Power Cord**

**ECU(V5) CONNECTION DIAGRAM**

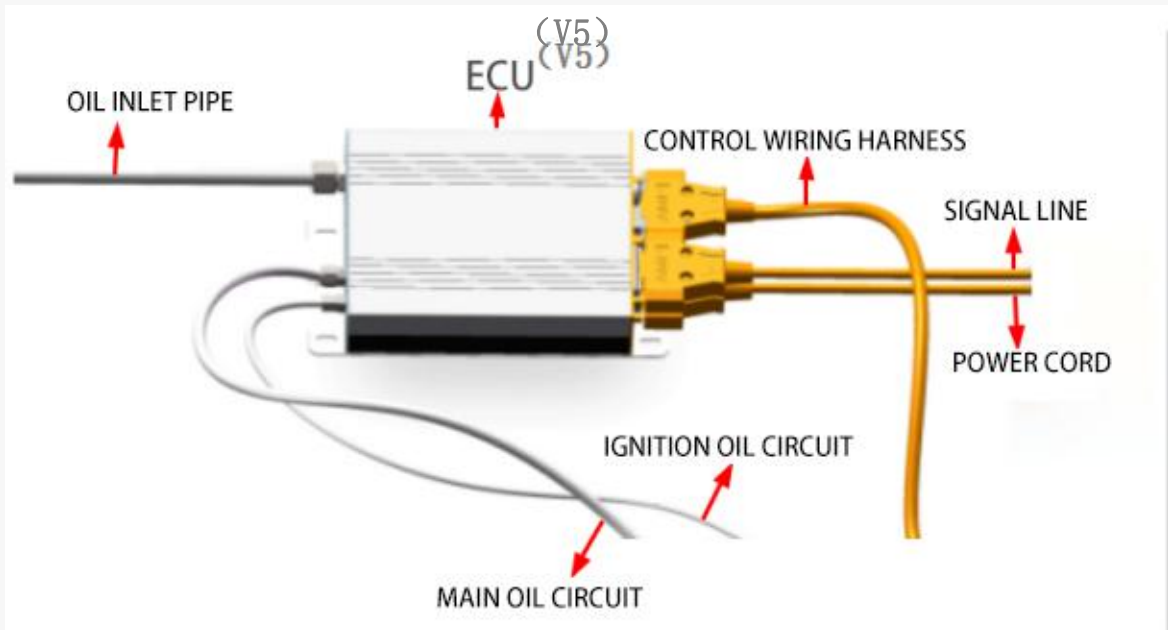

**ECU(V5) DETAILED INTRODUCTION**

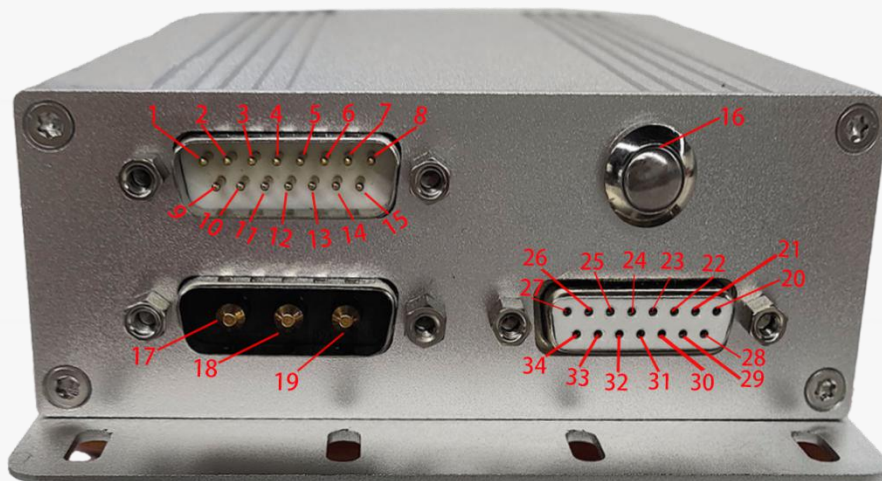



*pin 1-15 is an rs232/rs422 interface, used to connect external signal control devices and can be connected to rs232 or rs422 interfaces*

**WHEN CONNECTING TO RS232 INTERFACE:**

*Pin 1: reserved port*

*Pin 2: gsu data port*

*Pin 3: gsu positive pole of power supply*

*Pin 4: gsu negative pole or ground wire of power supply*

*Pin 5-8: reserved port*

*Pin 9: ppm throttle*

*Pin 10: ppm switch*

*Pin 11: ppm positive pole of power supply*

*Pin 12: ppm negative pole of power supply*

*Pin 13: rx port of rs232*

*Pin 14: tx port of rs232*

*Pin 15: rs232 ground wire*

*note: the rs232 signal cable supports both 232 serial port control and ppm control.*

**WHEN CONNECTING TO RS422 INTERFACE:**

*Pin 1: reserved port*

*Pin 2: gsu data port*

*Pin 3: gsu positive pole of power supply*

*Pin 4: gsu negative pole of power supply or ground level*

*Pin 5: rs422 t+mouth*

*Pin 6: rs422 t-mouth*

*Pin 7: rs422 r+mouth*

*Pin 8: rs422 r-mouth*

*Pin 9-15: reserved port*

**OIL PUMP BUTTON:**

*number 16: oil pump button, used to control the oil output of the oil pump*

**POWER INTERFACE:**

*connect the power interface to a 20-32v power supply*

*Number 17: reserved, the first reserved port*

*Number 18: positive pole, positive pole of power supply*

*Number 19: negative pole, power supply negative pole*

**SIGNAL INTERFACE:**

*used for connecting with the engine signal plug*

*Pin 20-22: interface for starting motor b*

*Pin 23-25: interface for starting motor a*

*Pin 26: negative pole of temperature sensor*

*Pin 27: positive pole of temperature sensor*

*Pin 28-30: interface for starting motor c*

*Pin 31-32: fire head ground wire interface*

*Pin 33: interface of huotou 2*

*Pin 34: interface of fire head 1*



**OIL INLET**

*number 35:oil inlet, connected to the fuel tank*

**OIL OUTLET**

*number 36:oil outlet, responsible for supplying oil to the main oil circuit of the engine*

*number 37:oil outlet, responsible for supplying oil to the engine ignition oil circuit*

**CONNECT AS SHOWN IN THE FOLLOWING DIAGRAM ECU (V5)**

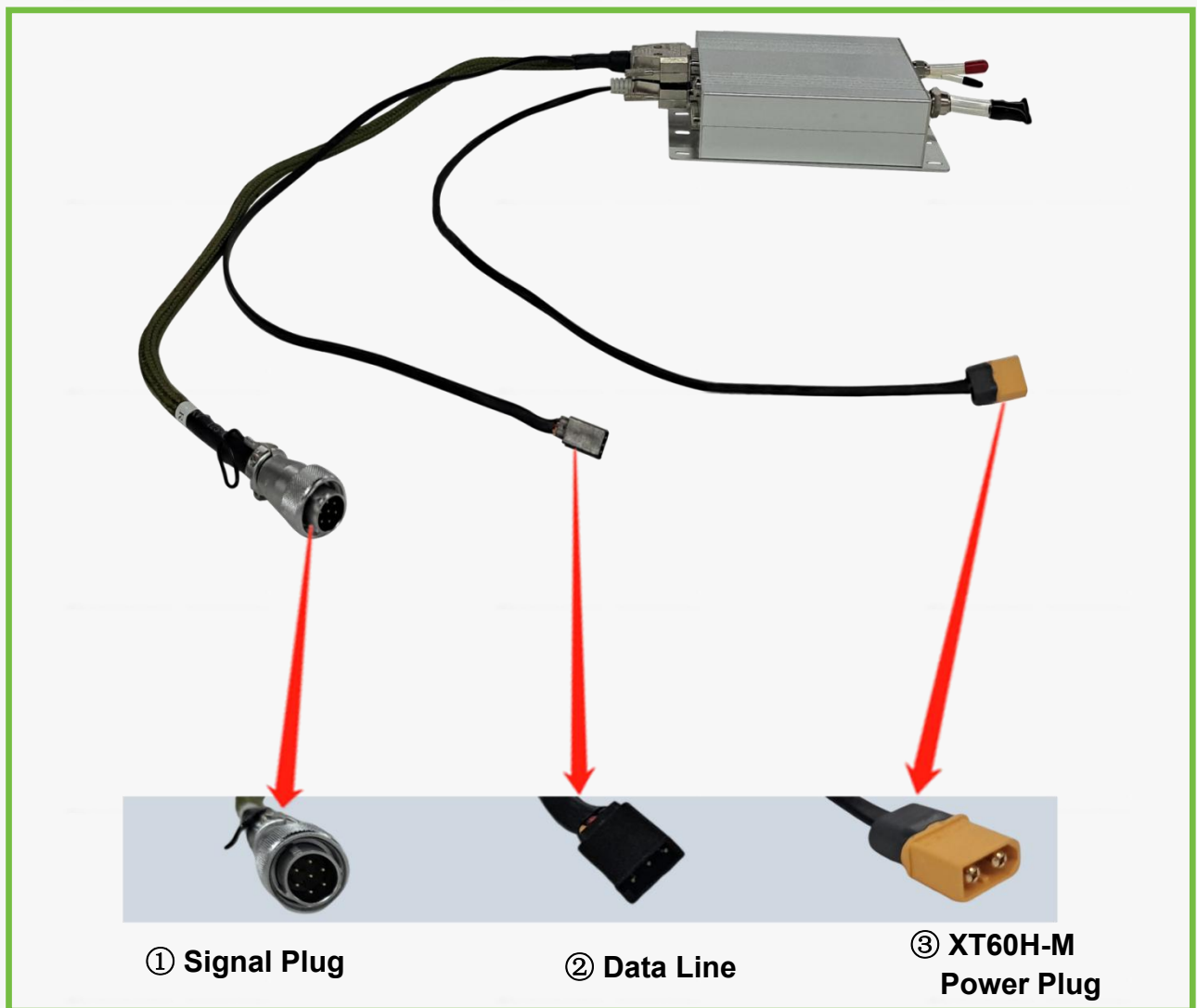

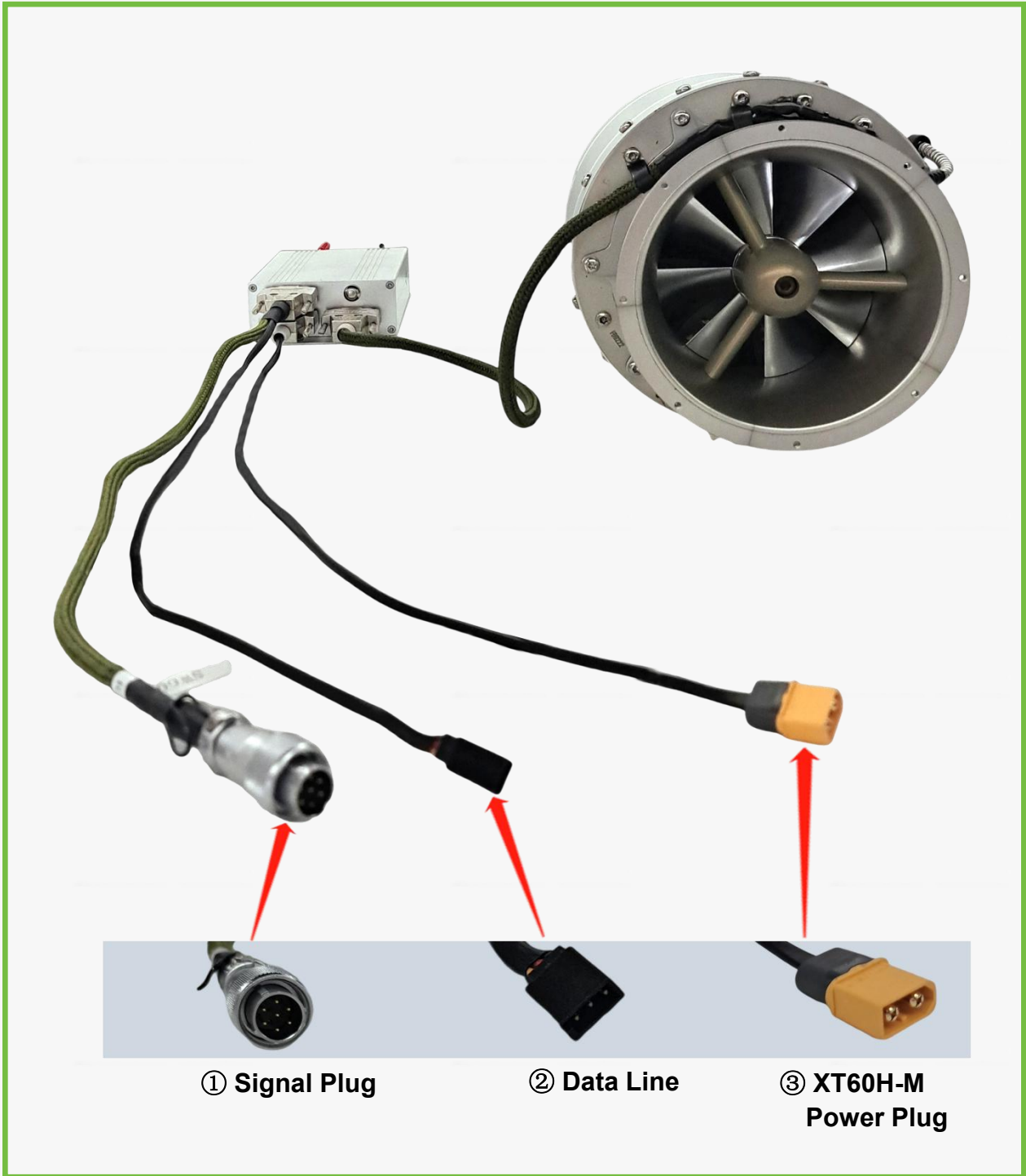

③ XT60H-M  
Power Plug

② Data Line

① Signal Plug

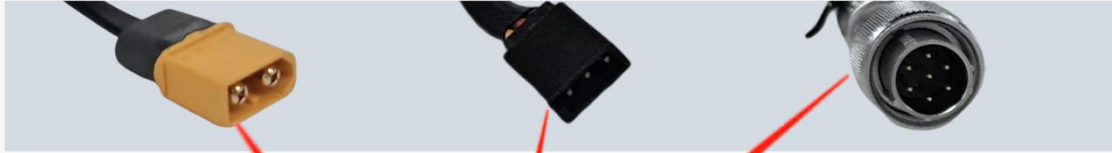



CONNECT AS SHOWN IN THE DIAGRAM BELOW, ECU (V5) IS CONNECTED TO THE COMPUTER THROUGH AN UPGRADE TOOL

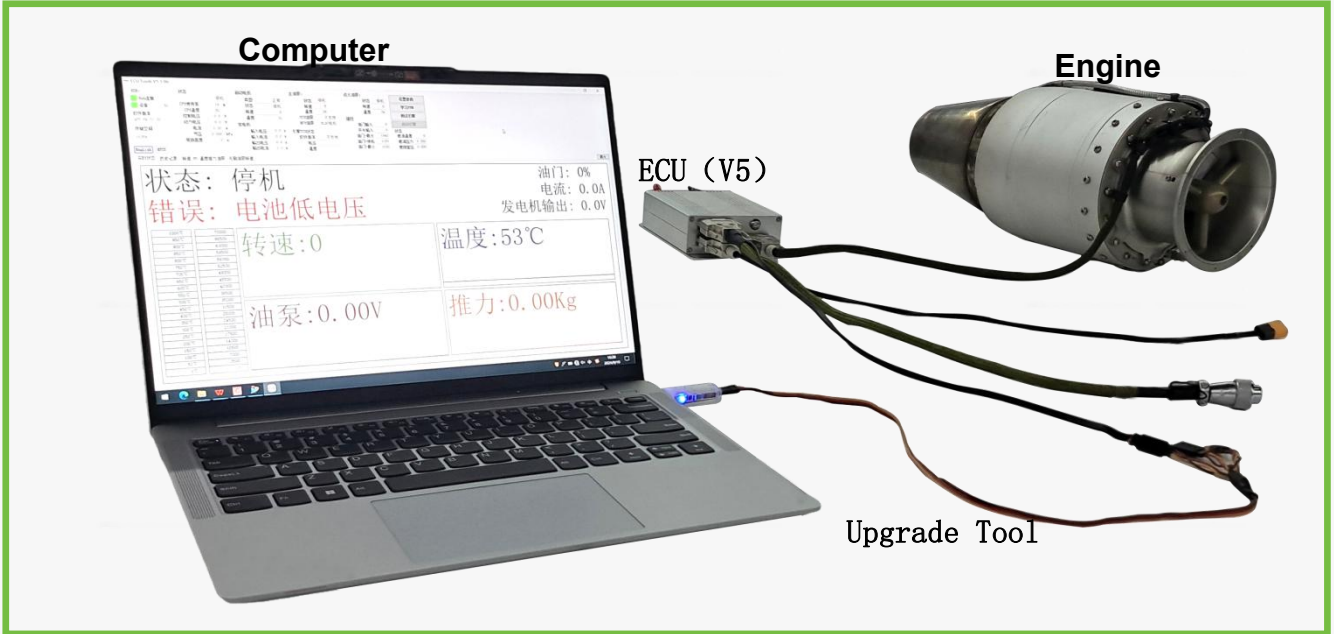

CONNECT THE BATTERY AS SHOWN IN THE FOLLOWING DIAGRAM

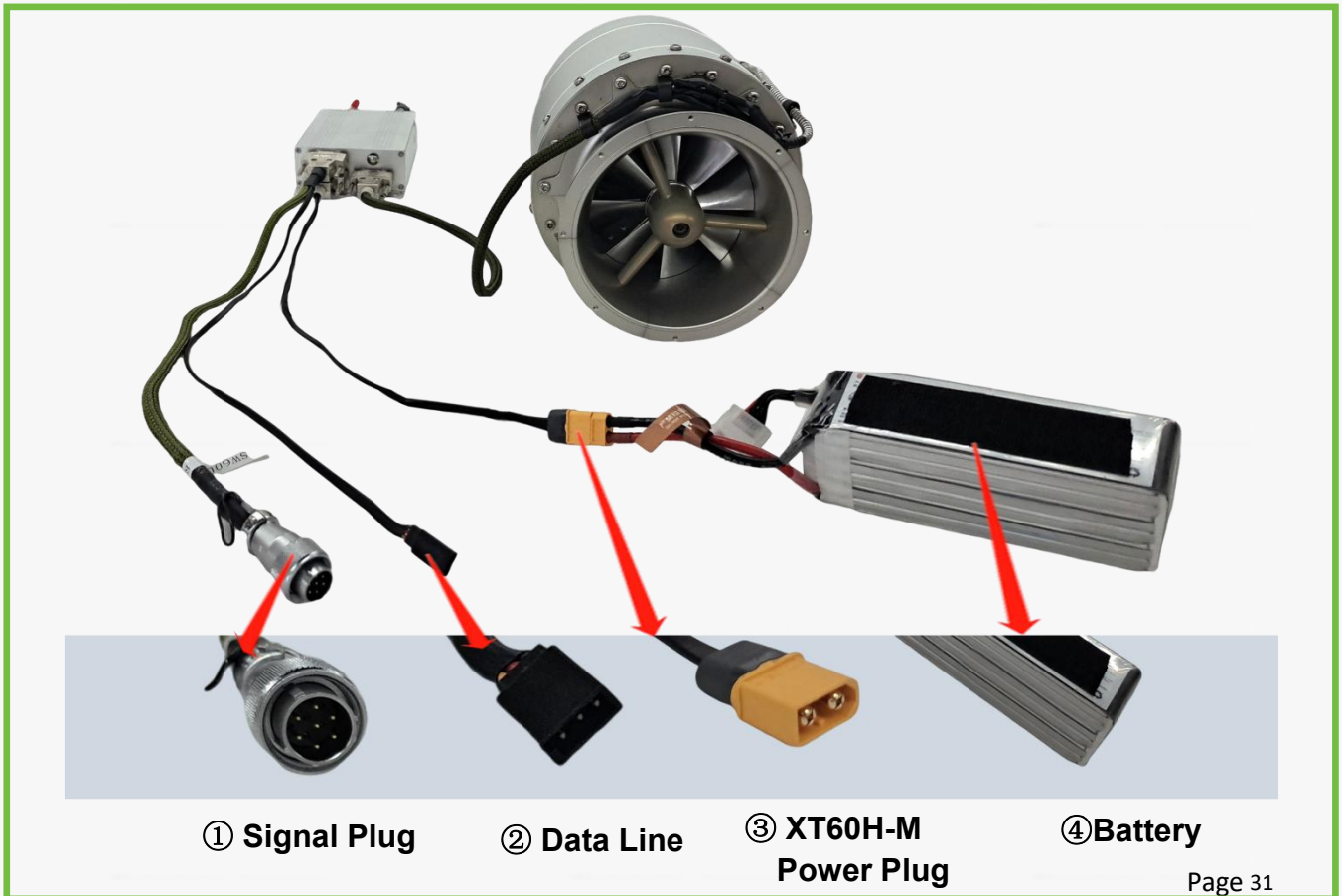

## SOFTWARE UPGRADE

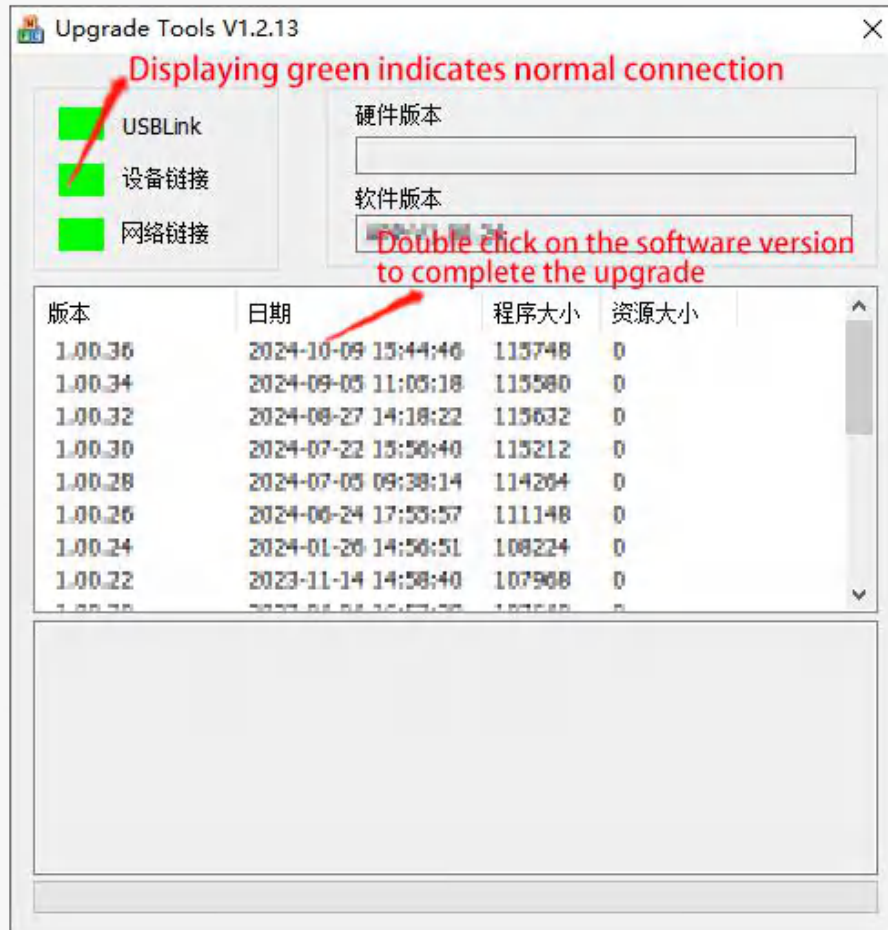

1. after the hardware is ready, log in to the swiwin website <http://www.swiwin.com> download upgrade tools.

2. open upgrade tools to upgrade the software, double-click to select the corresponding software version, and wait for the upgrade to complete.

## DATA DOWNLOAD

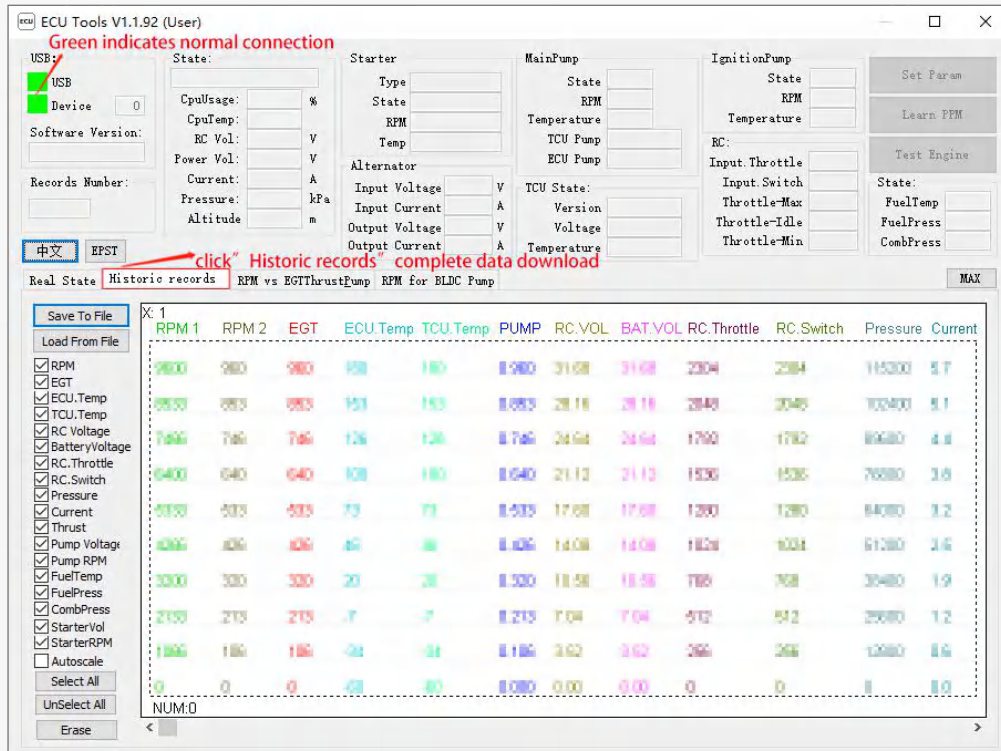

**Green indicates normal connection**

**click "Historic records" complete data download**

RPM 1	RPM 2	EGT	ECU.Temp	TCU.Temp	PUMP	RC.VOL	BAT.VOL	RC.Throttle	RC.Switch	Pressure	Current
980	980	980	158	180	1.980	31.08	31.08	2304	2384	115300	5.7
980	980	980	151	143	1.980	28.18	28.18	2848	3048	102400	5.1
786	786	786	126	126	1.786	24.64	24.64	1700	1782	86680	4.4
640	640	640	108	180	1.640	21.12	21.12	1336	1536	76280	3.8
510	510	510	73	73	1.510	17.08	17.08	1200	1280	64080	3.2
406	406	406	46	46	1.406	14.08	14.08	1824	1034	61280	2.6
300	300	300	20	28	1.300	11.58	11.58	788	768	38480	1.9
210	210	210	7	7	1.210	7.04	7.04	912	512	28080	1.2
186	186	186	-81	-81	1.186	3.62	3.62	366	366	12880	0.6
0	0	0	-68	80	1.080	0.00	0.00	0	0	1	0.0

1. after the hardware is ready, log in to the swiwin website <http://www.swiwin.com> download ecu tools (user) software.

2. open the ecu tools (user) software, click on "history" and wait for the data to load, then click on "save data" to complete.

## MODIFY BAUD RATE/CHANGE SETTING PARAMETERS

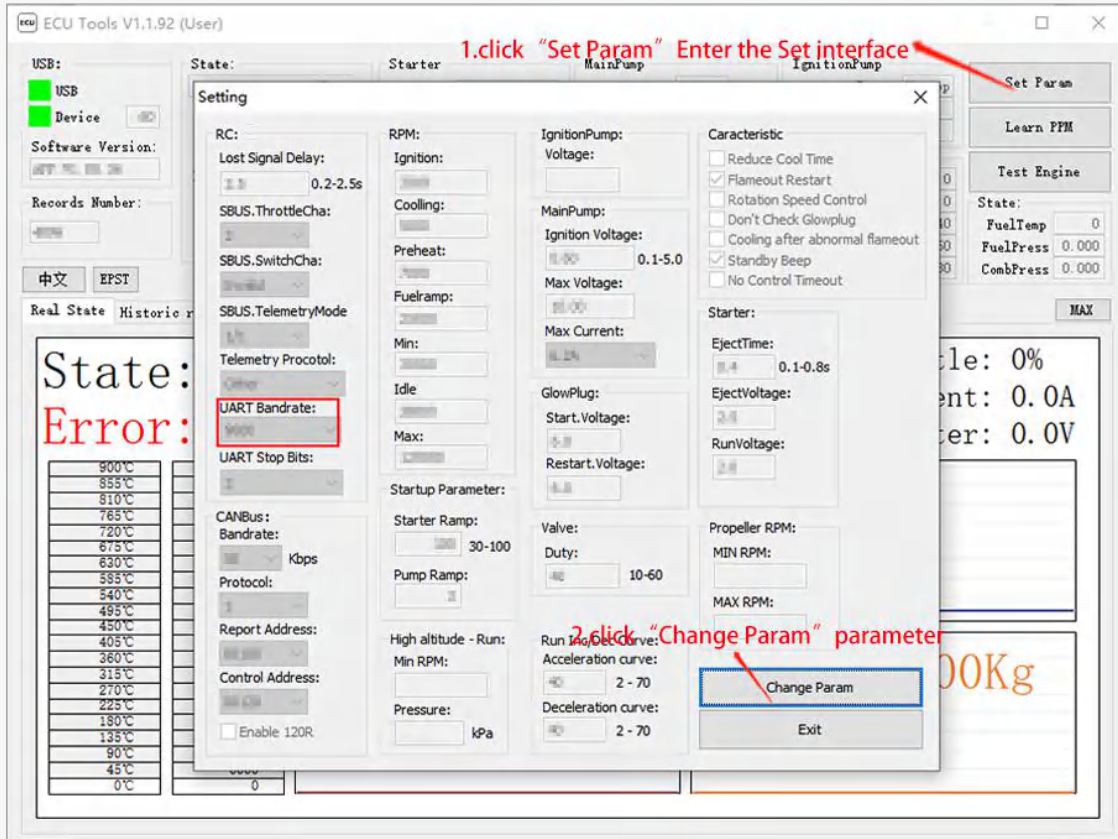

1. after the hardware is ready, log in to the swiwin website <http://www.swiwin.com> download ecu tools (user) software.

open the ecu tools (user) software, click "set parameters" to open the settings interface, and click "modify" to modify the settings and parameters.

## CANCEL REMOTE CONTROL SIGNAL LOSS MONITORING

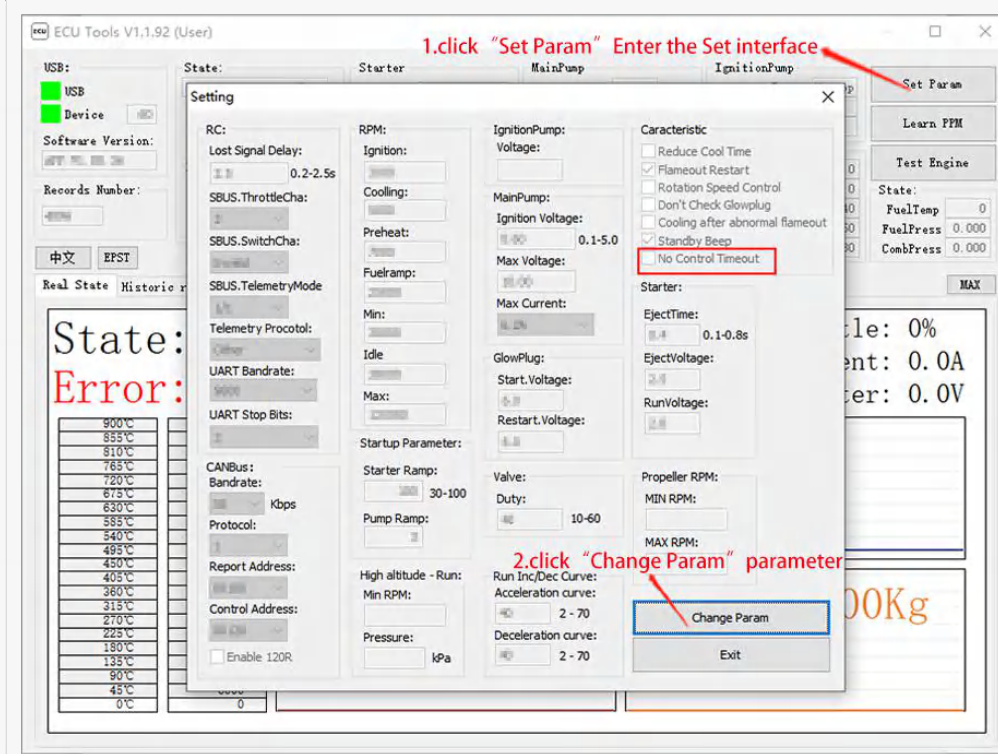

open the ecu tools (user) software, click on "set parameters", in the "characteristic parameters" column, check "cancel remote control signal loss monitoring". attention: after selecting "cancel remote control signal loss monitoring", the ecu will continue to execute the last command of the engine after receiving the signal interruption. if "cancel remote control signal loss monitoring" is not selected, the engine will stop directly after 2.5 seconds of signal interruption and immediately enter the cooling state.

you can also use the same method to change "acceleration cooling", "shutdown restart", "speed closed-loop control", etc.

**note: at the factory, all parameters and characteristic parameters of the engine have been set according to the engine performance and customer requirements. please make sure to communicate with swiwin after-sales personnel before making any changes.**

## 6. ENGINE DEBUGGING

### 6.1 SETTING OPERATION MODE

*before running the engine for the first time, please check if the desired engine starting method has been set. you can prepare the necessary tools in advance based on the chart below.*

STARTUP METHOD	REQUIRED SOFTWARE/HARDWARE	WIRE HARNESS CONNECTION
232/422 SERIAL PORT STARTUP	ZK V0.1.32	THE SIGNAL LINE+RS232/422 SERIAL PORT TOOL
FLIGHT CONTROL	FLIGHT CONTROL SOFTWARE	ECU TO FLIGHT CONTROL ADAPTER CABLE

*choose the correct battery type sw600pro requirements for engine power supply voltage : 18V-32V。*

### 6.2 CHECKLIST

*preparation before starting the engine*

- check the battery voltage.*
- prepare at least one co2 fire extinguisher. prepare earplugs and other noise proof personal protective equipment.*
- check the fuel pipeline to ensure that it is clean, unobstructed, and not bent. ensure that the fuel tank to ecu and ecu to engine section oil pipes are filled with fuel and there is no rich fuel inside the engine. ensure that the intake valve of the fuel tank is open. if there is no intake valve in the fuel tank or the intake valve is not open, it will cause the oil circuit to be blocked and the engine to fail to start.*
- confirm that 3% -5% lubricating oil is mixed in the fuel.*
- the fuel tank is full, and the sw600pro engine has a fuel consumption of 1690g/min. the sufficient fuel level will be determined based on the flight time you have booked.*
- the engine wiring harnesses are connected correctly, the remote control throttle calibration is normal, or the handheld terminal/ground station data feedback is normal.*

- the engine is firmly fixed, ensuring the safety of the surrounding environment, and checking that there are no debris within a range of 10 to 20 meters near the engine intake and exhaust nozzle.
- check if there are any other personnel within a range of 10 to 20 meters near the engine intake and exhaust nozzle.

### 6.3ENGINE START AND STOP

the checklist must be checked and all wiring harnesses of the engine must be connected before starting the engine.

### 6.4 PC CONTROL START AND STOP

- open the zk software. click on 'throttle control', and all parameters on the zk interface will return normally. click 'start' to start. if there is no feedback on the zk interface, click the button in the upper left corner of the page to select a different com channel or check the compatibility between the serial port tool and the computer.
- after confirming the feedback, use the gsu testing function or directly use the shortcut button on the ecu to fill the fuel inlet pipe with fuel. pay attention to stopping the fuel pump immediately when the fuel level enters the engine to prevent the engine from becoming rich in fuel and spraying a large fire when starting. press and test the ignition solenoid valve and main solenoid valve. if you hear a "click click" sound, it indicates that the solenoid valve is functioning properly. test the starter motor (counterclockwise rotation of impeller), ignition head (current changes on the test function interface), and determine that all engine components are working properly before starting the test.
- click "start" to start the engine. after reaching idle speed, control the engine speed through the throttle lever, and click "stop/cooling" to stop the engine.

## 7. ENGINE OPERATING STATUS DESCRIPTION

DISPLAY NAME	EXPLAIN
stop	the remote control fine-tuning is in the off gear or the engine control software has not sent a start command to the ecu.

get ready to start	the engine ecu receives the start command, and the engine is ready to start. this stage is very short, and the display shows that the engine will immediately enter the ignition state after the start is ready.
ignition	when in ignition state, the engine spark plug is energized, the ignition solenoid valve opens, the engine completes ignition, and the starter motor drives the engine to reach ignition speed, causing the internal temperature of the engine to rise.
preheat	entering the preheating state, the starter motor continues to drive the engine speed to increase by 1000-2000 revolutions per minute, and the internal temperature of the engine continues to rise.
accelerate	entering the acceleration phase, the starter motor continues to drive the engine speed to increase to the clutch disengagement speed, the starter motor stops working, the internal temperature of the engine reaches above 100 °C, and ignition is successful.
function	after the acceleration phase is completed, the engine speed reaches idle, and thereafter, the engine speed needs to be controlled through the throttle, with 100% throttle corresponding to the maximum engine speed.
cooling	adjust the remote control to the shutdown cooling gear, and the engine starter motor drives the compressor wheel to run at a lower constant speed until the internal temperature of the engine drops below 100 °C, and then the engine stops.
engine not detected	the connection between the engine and ecu is disconnected.
engine model	the gsu operating interface displays the engine model within the white box below the swiwin logo.
time	indicates the total time the engine has been running this time
speed	gsu operating interface, "rpm" represents the real-time engine speed during operation.
temperature	gsu operation interface, "temperature" represents the real-time internal temperature of the engine during operation.



oil pump power	on the gsu operation interface, "oil pump" represents the real-time oil pump power during engine operation.
remote control throttle	gsu operation interface, "remote control" represents the real-time throttle status during engine operation.

## 8. FREQUENTLY ASKED QUESTIONS AND ANSWERS

### 8.1 COMMON PROBLEM ELIMINATION

PROBLEM DESCRIPTION	CAUSE ANALYSIS	REMEDIAL MEASURES
engine ignition failure	the fuel pipe is not filled with fuel in advance, or the pipe is bent or blocked spark plug malfunction	fill the fuel pipe with fuel using the gsu testing function when using the gsu "test flame", there is no current displayed or no bright spot can be observed from the tail nozzle. in this case, contact swiwin after-sales service to return to the factory for repair
engine startup failure	low battery starting motor malfunction spark plug malfunction	battery charging depot repair depot repair
unable to reach maximum speed	oil pump issue oil circuit blockage	check if the oil pump and the entire oil circuit are unobstructed
engine ignition successful but startup process aborted	there are bubbles in the fuel supply pipe the oil pump is not working	oil circuit leakage, check all quick connectors
unstable exhaust temperature or engine speed	remote control antenna signal is interfered with	identify sources of interference

### 8.2 ANALYSIS OF ECU ERROR FAULTS

*during the operation of the engine, if there is a signal malfunction, the ecu will automatically report an error. the following table explains these faults.*

ERROR NAME	EXPLAIN
over time	during ignition: temperature remains unchanged for 20 seconds forced cooling: time exceeding 60 seconds
low battery voltage	the voltage of the power battery is lower than the minimum value (the minimum value can be modified) the voltage of the remote control receiver is below 4v
fire head malfunction	no flame current detected
abnormal oil pump	unable to connect to the oil pump motor controller (only supported on brushless motor version)
starting motor malfunction	during ignition: the engine speed cannot reach the ignition speed
low rotational speed	when igniting: the engine speed drops to 50% of the ignition speed during preheating: the engine speed drops below the ignition speed during acceleration: the engine speed drops below the warm-up speed during operation: the engine speed is lower than the set minimum speed
unstable rotational speed	during acceleration: engine rpm fluctuates up and down during acceleration: the engine speed drops significantly
high temperature	during ignition: the exhaust temperature is greater than the set maximum temperature value during preheating: the exhaust temperature is higher than the set maximum temperature value during acceleration: the exhaust temperature is greater than the set maximum temperature value for 4 seconds
low temperature	during preheating, there is a significant decrease in exhaust temperature during acceleration, there is a significant decrease in exhaust temperature
temperature sensor malfunction	during operation: exhaust temperature below 200 degrees celsius
lost remote control signal	remote control input signal lost, time exceeds set value
high starting motor	the temperature of the starter motor controller is too high (only

temperature	supported in the brushless motor version)
high oil pump temperature	the temperature of the oil pump motor controller is too high (only supported in the brushless motor version)
current overload	the working current of the ecu exceeds the design limit, and the current limit of different versions of the ecu varies
engine offline	ecu did not detect engine connection (only supported by bus controller version)

## 9. COMPATIBILITY

*if using zk or flight control software to control the engine, the connection between the engine and your device involves compatibility issues.*

### 9.1 COMPATIBILITY OF SERIAL PORT ADAPTER CABLE CONNECTORS

NAME	PERFORMANCE INDEX	COMPATIBILITY
RS232 ADAPTER YHL-B232	USB2.0,COMPATIBLE USB1.1 SUPPORT RS232 THREE WIRE SERIAL PORT INTERFACE USB BUS FOR DIRECT POWER SUPPLY WITHOUT THE NEED FOR AN EXTERNAL POWER SOURCE EQUIPPED WITH A SET OF 5V/500MA POWER OUTPUTS	SUPPORT COMPUTER SYSTEMS : WINDOWS2000、WINDOWSXP、WINDOWS SERVER 2003 (32、64 位)/VISTA/WINDOWS 7 (32、64 位)、WINDOWS 8、WINDOWS10

## 9.2 UPGRADER COMPATIBILITY

NAME	PERFORMANCE INDEX	COMPATIBILITY
UPGRADER (ZK-LINK V1.4)	-----	SUPPORT COMPUTER SYSTEMS : WINDOWS7、WINDOWS 8、WINDOWS10

## 10. STORAGE AND LUBRICATION

*all models of engines from swiwin company can use kerosene or diesel as fuel, and are mixed with 3% -5% lubricating oil. this mixed lubricating oil is also used in the bearing lubrication system, and it is recommended to use swiwin brand or mobil pegasus no.2 lubricating oil.*

*the engine has been stored for more than 3 months. to prevent bearing corrosion, it is recommended to lubricate the engine thoroughly with fuel, place it vertically, and seal it with a sealed bag. if there are ground testing conditions, ignition testing can provide better maintenance for the engine. if necessary, you can also contact after-sales personnel to return to the factory for maintenance.*

## 11. ENGINE MAINTENANCE AND UPKEEP

*the maintenance requirements and cycle of the product, including cleaning, replacement of parts, etc.*

*1. maintenance plan: regularly inspect and replace lubricating oil, air filters, and other components of the engine.*

*2. daily maintenance: regularly check the fastening of various connecting parts and pipelines of the engine, and clean the surface of the engine.*

*3. troubleshooting: if encountering problems such as decreased engine performance or*

*abnormal noise, follow the maintenance manual and troubleshooting process for operation.*

*every hour of engine operation, please check the following:*

- *is there any burning or discoloration on the engine casing.*
- *is the engine mount intact.*
- *is the air inlet and impeller intact.*
- *is there any leakage in the oil system and is the oil filter clogged.*
- *bearing: manually rotate the rotor and carefully distinguish the bearing sound. if there is a "rustling" sound, the bearing may be slightly damaged due to impurities or improper cooling. it is recommended to use clean fuel or replace the oil filter. if the bearings are clearly damaged after inspection, it is prohibited to use the engine again. you can log in to the swiwin official website and contact after-sales personnel to replace the bearings.*

*maintenance cycle: the regular maintenance cycle for the model version engine is **25 hours per accumulated operating time.***

## **12. AFTER SALES SERVICE**

### **limited liability warranty**

*the service life of a turbojet engine is directly related to the operating environment and operating techniques. the turbojet engine uses the simplest structure to achieve the most extreme working state, and each component is designed and produced to the extreme. the working conditions are extremely harsh. do not disassemble the intake duct and main shaft structure by yourself. once the turbojet engine is disassembled, it must be precisely reinstalled according to specifications to achieve its original performance. random assembly will cause the turbojet body to lose balance, and high-speed operation will cause serious consequences.*

*buyers of new swiwin engines are entitled to a one-year or 25 hour natural damage warranty. if you encounter any questions or operational issues during use, please contact the sales department.*



*if you need the engine to be returned to the factory for maintenance and repair, please log in to the official website of swiwin company <http://www.swiwin.com> or "swiwin power" official account to contact customer service, fill in the engine maintenance application form, and prepare the following relevant contents:*

ENGINE MAINTENANCE APPLICATION FORM			
NAME		THE DATE OF ISSUANCE	
Shipping Address			
Fault Description	_____ Model:		
Other Service Requirements	<input type="checkbox"/> Technical Consultation <input type="checkbox"/> Engine Maintenance <input type="checkbox"/> Accessories Procurement		

SWIWIN TURBOJET EQUIPMENT CO.,LTD

Tel: 15531598038

Email: [swiwin@foxmail.com](mailto:swiwin@foxmail.com)

Web: <http://www.swiwin.com>

Add: 66 Jianye East Road, High-tech district,  
Baoding, Hebei, China

