

**QUICK START (PRO-K SERIES) ENGINE
TECHNICAL MANUAL**



you and us

welcome to the age of turbojet models! swiwin is ready to take you to experience different flight fun!

firstly, please carefully read this manual to have a comprehensive understanding and impression of the engine, engine components, and operating process, in order to ensure the safe operation and optimal performance of the engine.

this manual will introduce you to how to install, operate, and maintain the engine. if you still have any questions, please feel free to contact us.

we will wholeheartedly provide you with sales, technical, and after-sales

support services for the swiwin quick start engine. this instruction

manual aims to provide users with detailed usage guidelines and

recommendations to ensure the safety of the engine operation and

optimal performance.



CATALOGUE

1.PRODUCT OVERVIEW.....	3
2.PRODUCT DIMENSION DIAGRAM.....	4
2.1 DIMENSIONAL DRAWING.....	4
2.2 BASIC ENGINE PARAMETERS.....	5
2.3 PARAMETERS OF ENGINE OPERATION CONTROL.....	6
3. SAFETY INSTRUCTIONS.....	7
4.ENGINE INSTALLATION, FIXATION, AND CONNECTION.....	9
5. ENGINE USAGE INSTRUCTIONS.....	10
5.1 LIST OF ENGINE ACCESSORIES.....	10
5.2 OVERVIEW OF ENGINE CONNECTIONS.....	11
5.3 DATA CONNECTION DEFINITION.....	12
5.4 COMMUNICATION PROTOCOL.....	13
5.5 INSTRUCTIONS FOR CONNECTING ENGINES WITH DIFFERENT STARTING MODES.....	19
5.6 ONE CLICK START.....	22
5.7 GSU USER MANUAL.....	23
5.8 ECU (V4) INSTRUCTIONS.....	27
6. ENGINE DEBUGGING.....	32
6.1 SET OPERATION MODE.....	32
6.2 CHECKLIST.....	32
6.3 ENGINE START AND STOP.....	33

6.4 USE REMOTE CONTROL TO START AND STOP.....	33
6.5 PC SIDE CONTROLS START AND STOP.....	35
7.ENGINE OPERATING STATUS.....	36
8. COMMON PROBLEM ELIMINATION.....	37
8.1 COMMON PROBLEM ELIMINATION.....	37
8.2 ECU ERROR FAULT ANALYSIS.....	38
9. COMPATIBILITY.....	40
9.1 COMPATIBILITY OF SERIAL PORT ADAPTER CABLE CONNECTORS.....	40
9.2 UPGRADER COMPATIBILITY.....	40
10. STORAGE AND LUBRICATION.....	41
11. ENGINE MAINTENANCE AND UPKEEP.....	41
12. AFTER SALES SERVICE.....	42

1.PRODUCT OVERVIEW

swiwin professional quick start edition engine has a high degree of overall design integration, easy installation, and convenient operation. the engine consists of two main parts: the main body and an external ecu controller.

ELECTRONIC COMPONENTS INTEGRATED WITHIN THE ENGINE BODY:

- *tcu (electronic control unit)*
- *brushless starter motor*
- *engine control cable*



COMPONENTS INTEGRATED WITHIN THE ECU CONTROLLER:

- *ecu (electronic control unit)*
- *brushless pump*
- *power supply, engine control, signal transmission aviation plug connector*



2.PRODUCT DIMENSION DIAGRAM

2.1 DIMENSIONAL DRAWING

SW300Pro-K

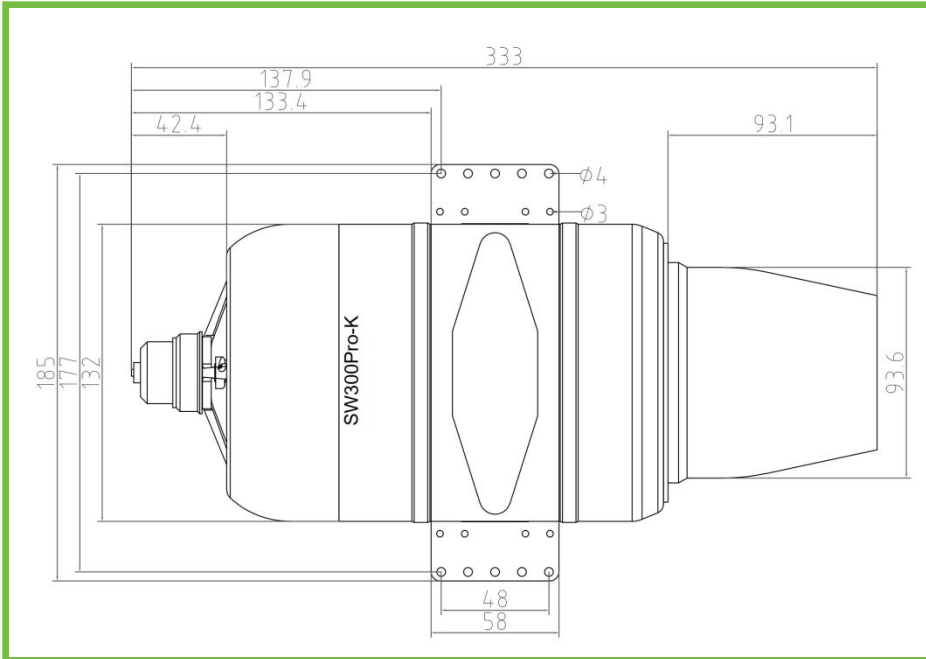

SW400Pro-K

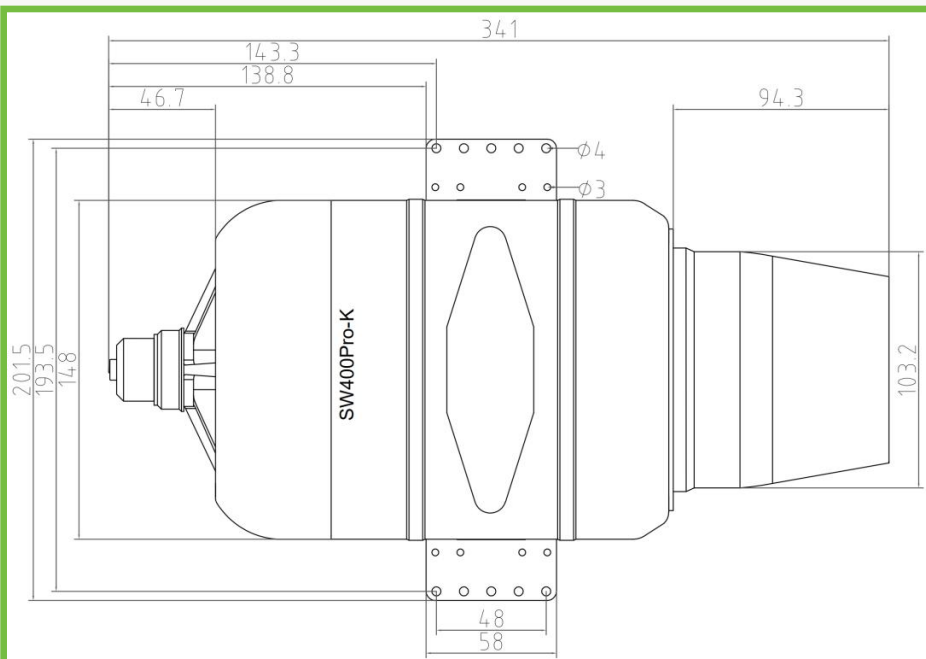

2.2 BASIC ENGINE PARAMETERS

PROJECT	SW300Pro-K	SW400Pro-K
thrust	30kg	40kg
diameter (mm)	132mm	148mm
length (mm)	333mm	341mm
weight	2620g	3240g
ecu weight	353g	436g
usage temperature	-40°C~50°C	-40°C~50°C
max usable height	12000m	12000m
maxi longitudinal overload during catapult takeoff	20g	20g
max allowable flight speed	300m/s	300m/s
supply voltage	4SLiPo battery, ≥3000mAh, 35C	4SLiPo battery, ≥3000mAh, 35C
starting system	one key electronic start	
rpm range	38,000-98,000	35,000-97,000
exhaust temperature	750°C	750°C
fuel consumption	820g/min	1000g/min
fuel	aviation kerosene	
lube oil	3%-5%	
maintenance Interval	25h/time	
start time	less than 30 seconds	

2.3 PARAMETERS OF ENGINE OPERATION CONTROL

PROJECT	SW300Pro-K	SW400Pro-K
pump voltage	1.34V	1.6V
rpm start up ramp	80%-100%	80%-100%
pump start up ramp	7-15	8-15
glow plug	6.6V-7V	6.6V-7V
valve	50	40
ignition rpm	3,000 rpm	3,000 rpm
preheat rpm	8,000 rpm	8,000 rpm
rpm off starter	18,000 rpm	23,000 rpm
rpm acc	25	40
rpm dec	25	40
max rpm	98,000 rpm	97,000 rpm
idle rpm	38,000 rpm	35,000 rpm
minimum speed	18,000 rpm	23,000 rpm
max temp	1000℃	1000℃
low volt	10V	10V
restart	close	
restart glow plug	same voltage as the ignition head	
pump limit	13V	13V
idle stable	8	8
pop-up time	0.4S	0.4S
ejection voltage	4V	4V
run voltage	5V	5V
rpm stable	50	20
cool	4,000 rpm	4,000 rpm

note: all the data were measured under the standard air pressure

3. SAFETY INSTRUCTIONS

safety notice:

thank you for using the swiwin micro turbojet engine. the working state of the turbojet engine is essentially highly extreme mechanical work, which poses a certain degree of danger. the operator must be familiar with the operating points and recognize the risks before use. careless operation can easily cause damage to the turbojet body and personal injury. please carefully read the operating instructions in the manual and strictly follow the operating regulations. if this is your first time operating a turbojet engine, please learn how to operate it under the guidance of experienced personnel. before starting the turbojet engine for the first time, please carefully read this manual.

safe distance:

the engine operates at extremely high rotational speeds. when the engine is running, it must maintain a safe distance from the aircraft, with a distance of 3 meters in front of the engine and 5 meters on both sides.

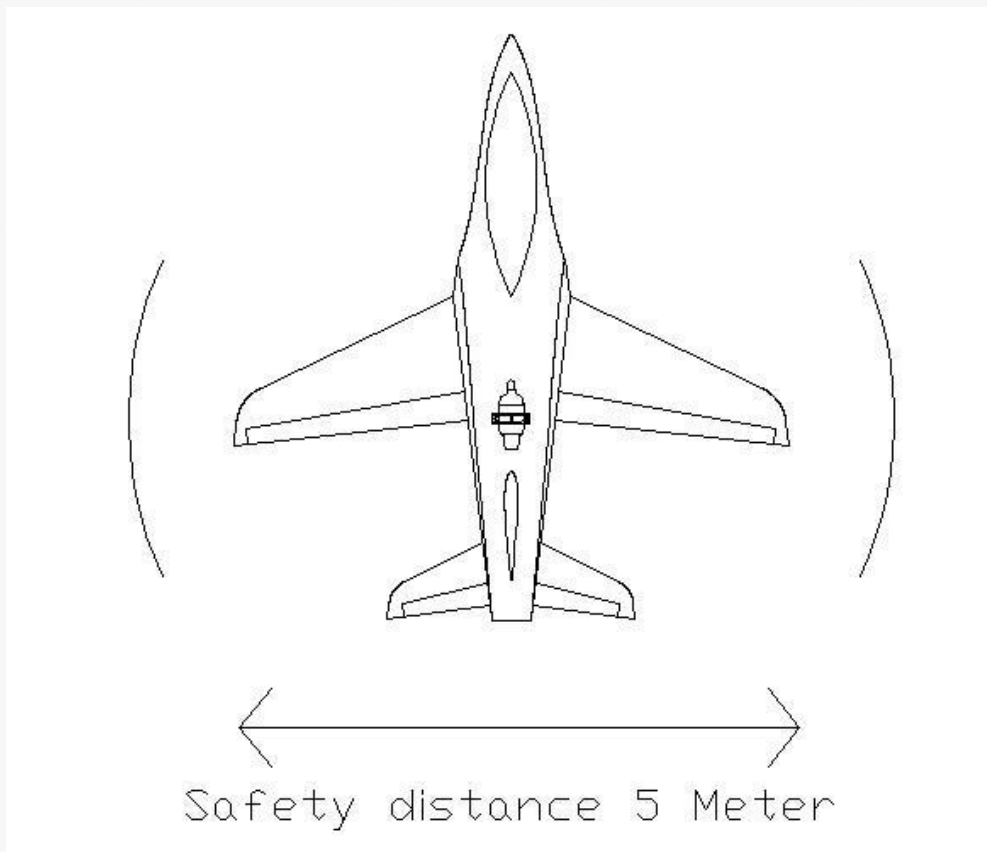

the following figure shows the hazardous areas during engine operation.

- confirm that no personnel have entered the hazardous area during operation.
- when operating the engine, safety goggles and earplugs must be worn.
- ensure that there are no debris that may be inhaled in the intake area.
- keep your fingers away from the intake area when operating the engine.
- prepare fire extinguishing equipment before operating the engine. (carbon dioxide fire

DANGEROUS AREAS DURING ENGINE START-UP AND IDLE

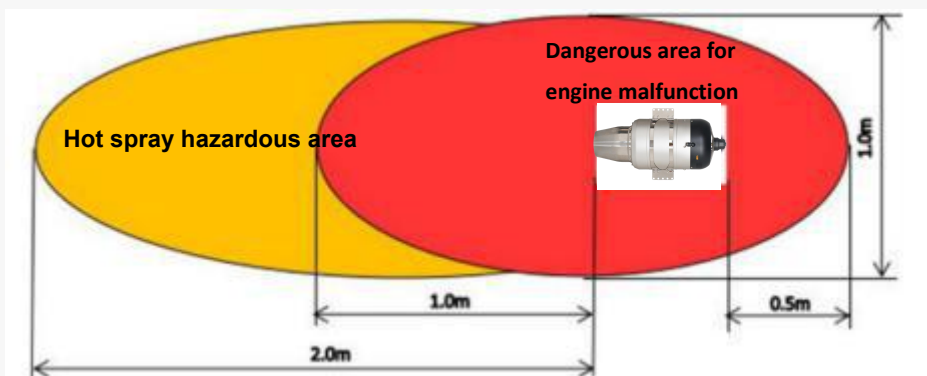

ENGINE 20% THROTTLE TO FULL THRUST DANGER ZONE

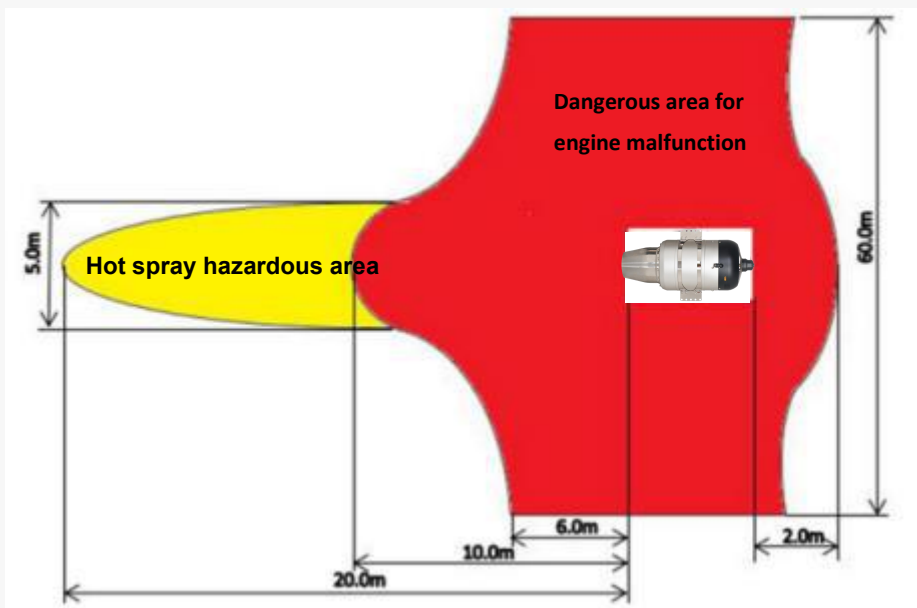

4.ENGINE INSTALLATION, FIXATION, AND CONNECTION

SWIWIN PROFESSIONAL EDITION (PRO SERIES) ENGINE INSTALLATION FIXED ENGINE

the swiwin professional edition engine is equipped with dedicated fixing clamps. before operating the engine, tighten and secure the clamps. be careful not to overtighten the fixing screws to prevent deformation of the engine casing from affecting the fixing effect.



SW300Pro-K













SW400Pro-K

the optimal installation position for the engine: rotate the engine to position the oil inlet at the 12 o'clock position

5. ENGINE USAGE INSTRUCTIONS

5.1 LIST OF ENGINE ACCESSORIES

open the package, the list of engine accessories is as follows

 <p>Engine body</p>	 <p>ECU (V4)</p>	 <p>GSU</p>
 <p>Fixed bracket</p>	 <p>Ball valve</p>	 <p>Oil filter</p>
 <p>Power cord</p>	 <p>Signal line</p>	 <p>Tubing</p>
 <p>Serial port tool</p>		

5.2 OVERVIEW OF ENGINE CONNECTIONS

open the packaging, familiarize yourself with each component, and connect them as shown in the following diagram

SW300Pro-K

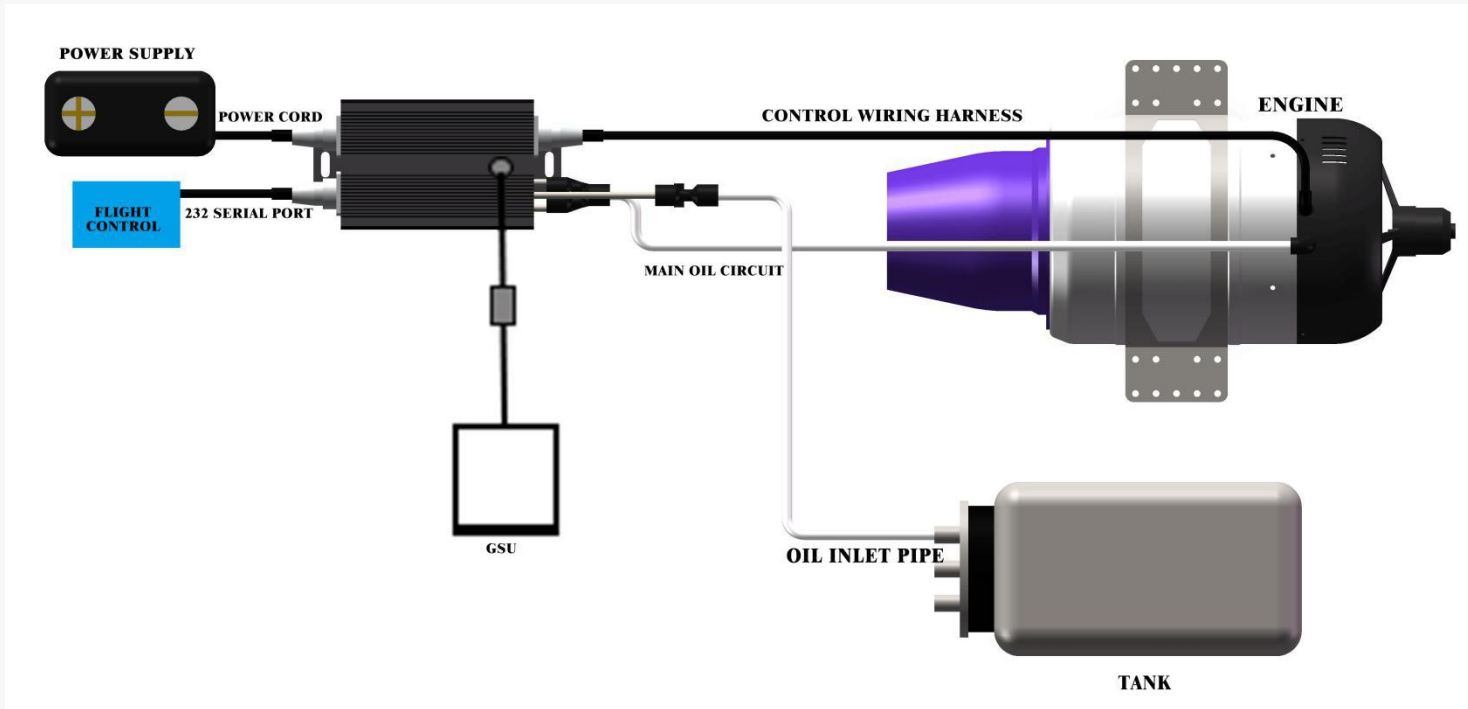

SW400Pro-K

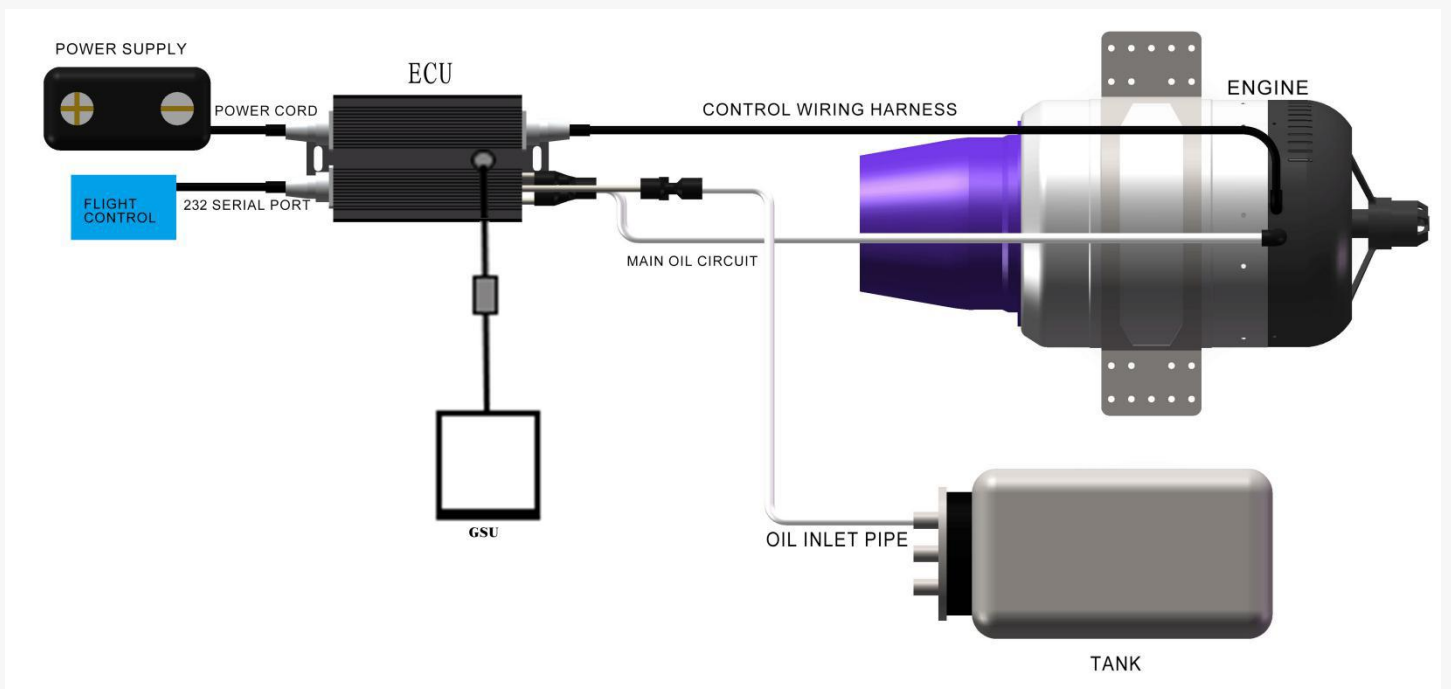

control wiring harness: the connecting wire between the engine and ecu.

power cord: the power cord is connected to the ecu at the aviation plug end, and the other end is connected to the power supply with an xt60 plug. the plug model can be customized according to needs.

signal line: the provided signal line defaults to the remote control operation mode. if there are special requirements, the signal line can be customized. the signal line is connected to the ecu at the aviation plug end, and the other end is divided into three wires, namely the switch (connected to the receiver switch channel), rs232 (connected to the 232 serial port tool for pc control), and throttle line (connected to the receiver throttle channel).

gsu:monitor: the monitor is connected to the ecu data cable and is used to display engine operation data.

power supply: professional quick start engine, recommended power supply voltage of 16.8-24v, capacity of 3000mah or larger.

after all wire harness connections are completed, the ecu emits a "drip drip drip drip" music prompt, indicating that the connections are intact.

5.3 DATA CONNECTION DEFINITION

the engine data connection is completed through the ecu, which has three sockets on the side, namely ws16j2 2-pin aviation plug, ws16j3 3-pin aviation plug, and ws16j7 7-pin aviation plug. the three plugs are respectively connected to the engine control line, power line, and signal line.

ECU POWER INTERFACE DEFINITION

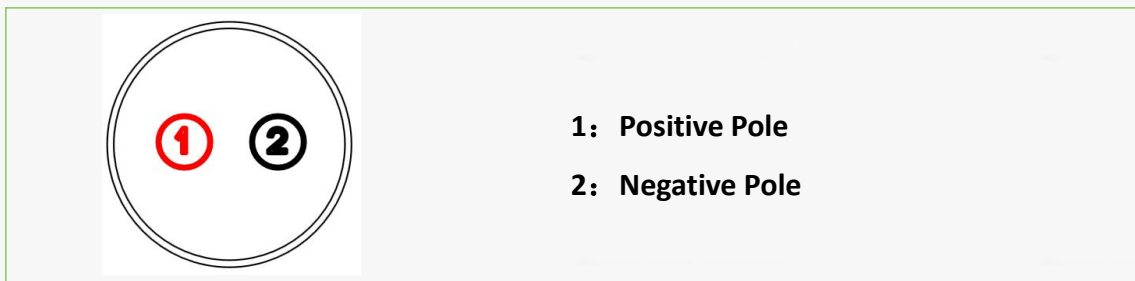

DEFINITION OF ECU CONTROL PLUG

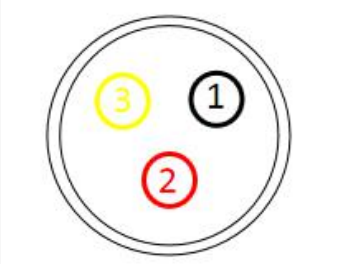

- 1: Negative Pole
- 2: Positive Electrode
- 3: Data

ECU SIGNAL PLUG DEFINITION (RS232)



- 1: Switch Data
- 2: Switch Positive Electrode
- 3: 232tx
- 4: Gnd
- 5: 232rx
- 6: Throttle Signal
- 7: Throttle Negative Pole

ECU SIGNAL PLUG DEFINITION (RS422)



- 1: R+
- 2: R-
- 3: Empty
- 4: Empty
- 5: t-
- 6: t+
- 7: Gnd

5.4 COMMUNICATION PROTOCOL

•ecu interface

supports rs232 or rs422 electrical interfaces

•serial port data format
uart: 2400/4800/9600/19200/38400/57600/115200 (other settings available)

data length: 8 bits

parity check: no

stop position: 1/2 position (adjustable)

•meaning of control command data packet

byte:0								byte:1								byte:2								byte:3																							
7	6	5	4	3	2	1	0	7	6	5	4	3	2	1	0	7	6	5	4	3	2	1	0	7	6	5	4	3	2	1	0																
Head (0xFF)								Cmd ID: 0								reserve								CRC																							
Head (0xFF)								Cmd ID: 1								SW								Throttle								CRC															
Head (0xFF)								Cmd ID: 2								reserve								Param								CRC															
Head (0xFF)								Cmd ID: 3								reserve																CRC															
Head (0xFF)								Cmd ID: 4								reserve								Ignition Pump Voltage								CRC															
Head (0xFF)								Cmd ID: 5								reserve								Acceleration curve								CRC															
Head (0xFF)								Cmd ID: 6								reserve								RPM_X								SW								CRC							
Head (0xFF)								Cmd ID: 7								set rpm																CRC															
Head (0xFF)								Cmd ID: 8																air pressure								CRC															

COMMUNICATION PROTOCOL · MEANING OF CONTROL COMMAND DATA PACKET

please note the supported protocol version numbers. please check the ecu status id6 for the current ecu protocol version number

COMMAND ID	EXPLAIN	SUPPORTED PROTOCOL VERSIONS
Cmd ID: 0	EMPTY CYCLE THE HOST DOES NOT CONTROL THE ECU, BUT THE ECU WILL RETURN TO THE ENGINE STATE TO MAINTAIN CONNECTION	1
Cmd ID: 1	CONTROL ENGINE STATUS (SW): 0 SERIAL PORT DOES NOT CONTROL THE ENGINE (PWM INPUT CONTROL MODE) 1. CONTROL THE ENGINE TO ENTER A STOP STATE (OVERHEATING WITHOUT COOLING) 2. CONTROL THE ENGINE TO ENTER STANDBY MODE (OVER TEMPERATURE AUTOMATIC COOLING) 3. CONTROL THE ENGINE TO ENTER THE RUNNING STATE NOTE: IF THE SWITCH IS NON-ZERO, THE SERVO CONTROL SIGNAL IS INVALID. CONTROL THE ENGINE THROTTLE: RANGE 0~1000 (REPRESENTING 0%~100% THROTTLE)	1 1 1 1 1

	<table border="1"> <tr><td>2</td><td>0 REACH 81900</td></tr> <tr><td>3</td><td>0 REACH 122850</td></tr> <tr><td>4</td><td>0 REACH 163800</td></tr> <tr><td>5</td><td>0 REACH 204750</td></tr> <tr><td>6</td><td>0 REACH 245700</td></tr> </table> <p>NOTE: IF RPM_X IS NON-ZERO, THE ID1 COMMAND IS INVALID. USE THE SW OF ID6 TO CONTROL THE ENGINE STATE AND THE RPM OF ID7 TO CONTROL THE ENGINE SPEED. THE NUMERICAL MEANING OF RPM_X REFERS TO THE RPM EXPLANATION IN ID7.</p>	2	0 REACH 81900	3	0 REACH 122850	4	0 REACH 163800	5	0 REACH 204750	6	0 REACH 245700	
2	0 REACH 81900											
3	0 REACH 122850											
4	0 REACH 163800											
5	0 REACH 204750											
6	0 REACH 245700											
Cmd ID: 7	CONTROL ENGINE SPEED (RPM) NUMERICAL RANGE: 0~4095 ENGINE RPM = RPM * 10 * RPM_X ATTENTION: CHOOSE THE APPROPRIATE RPM_X BASED ON THE MAXIMUM ENGINE SPEED. WHEN RPM_X IS 0, THE RPM OF ID7 IS INVALID.	4										
Cmd ID: 7	SET AMBIENT ATMOSPHERIC STATIC PRESSURE (AIR PRESSURE) NUMERICAL RANGE: 0~1024 AIR PRESSURE UNIT: HPA											

COMMUNICATION PROTOCOL · ECU STATUS DATA PACKET MEANING

please note the supported protocol version numbers. please check the ecu status id6 for the current ecu protocol version number

COMMAND ID	EXPLAIN	SUPPORTED PROTOCOL VERSIONS
cmd id: 1	rpm: engine rpm $val = \{byte2[7:0], byte1[7:0]\} * 10$ engine state: engine status $val = \{byte3[4:0]\}$ ecode: error code $val = \{byte4[1:0], byte3[7:5]\}$ temp: engine exhaust temperature (celsius) $val = \{byte4[4:2], byte5[7:0]\} - 50$ swst: the control status of the host (computer, flight control) to the ecu $val = \{byte4[6:5]\}$ 0: engine shutdown 1: engine standby 2: start/run	1 1 1 1 1
cmd id: 2	rpm: engine rpm $val = \{byte2[7:0], byte1[7:0]\} * 10$ radio voltage: receiver voltage $val = \{byte3[7:0]\}$ unit:0.1v $val = \{byte3[7:0]\}$ unit:0.2v	1 <=3 >=4

	power voltage: power electric voltage val = {byte4[7:0]} unit:0.1v val = {byte4[7:0]} unit:0.2v pump voltage: current voltage of oil pump val = {byte5[7:0]} unit:0.1v val = {byte5[7:0]} unit:0.2v	<=3 >=4 <=3 >=4
cmd id: 3	pm: engine rpm val = {byte2[7:0],byte1[7:0]} * 10 throttle: throttle val = {byte3[7:0]} unit:% pressure: atmospheric pressure val = {byte5[7:0],byte4[7:0]} * 2 unit:pa	1 1 1
cmd id: 4	pm:engine rpm val = {byte2[7:0],byte1[7:0]} * 10 current: ecu current current val = {byte4[0],byte3[7:0]} unit:0.1a thrust: engine thrust, no measurement module, output is 0 val = {bytr4[7:1],byte5[7:0]} unit:0.1kg	1 1 2
cmd id: 5	rpm:engine rpm val = {byte2[7:0],byte1[7:0]} * 10 ignition pump voltage: ignition oil pump voltage val = {byte3[7:0]} * 2 unit:0.01v curve increase: engine acceleration curve parameters val = {byte4[7:0]} curve decrease: engine deceleration curve parameters val = {byte5[7:0]}	1 1 1 1
cmd id: 6	rpm:engine rpm val = {byte2[7:0],byte1[7:0]} * 10 max rpm: maximum engine speed val = {byte3[7:0]} * 1000 unit:rpm max pump voltage: the maximum voltage of the learned oil pump val = {byte4[7:0]} unit:0.1v val = {byte4[7:0]} unit:0.2v protocol version: protocol version val = {byte5[7:2]} srate: current data update rate val = {byte5[1:0]} 0: 20hz 1: 50hz 2:100hz	1 1 1 <=3 >=4 1 1
cmd id: 7	rpm:engine rpm val = {byte2[7:0],byte1[7:0]} * 10	2

	flow rate: fuel flow rate val = {bytr4[1:0],byte3[7:0]} unit:0.01l/min flow total: accumulated fuel consumption val = {byte5[7:0],byte4[7:2]} unit:0.1l	2 2
cmd id: 8	rpm:engine rpm val = {byte2[7:0],byte1[7:0]} * 10 max rpm: engine standby speed val = {byte3[7:0]} * 1000 unit:rpm esr: request the flight control to send atmospheric static pressure val = {byte4[5]} 0: no need for flight control to send atmospheric pressure 1: need the flight control to send atmospheric pressure scl: speed closed-loop state val = {byte4[4]} 0: speed open-loop state 1: speed closed-loop state startup time: engine startup time val = {byte4[3:0], byte5[7:0]} unit:0.1s	 3 3 4 4 4
cmd id: 9	rpm:engine rpm val = {byte2[7:0],byte1[7:0]} * 10 ecu temperature: ecutemperature (celsius) val = {byte3[7:0]} - 50 reserve: retain {byte4[7:0]} {byte5[7:0]}	5 5 5

● CONTROL MODEL

1.THROTTLE CONTROL MODE - THROTTLE AND ENGINE STATUS ARE UNDER THE SAME CONTROL COMMAND

engine status: id1 - sw

engine throttle: id1 – throttle

2.THROTTLE CONTROL MODE - THROTTLE AND ENGINE STATUS UNDER DIFFERENT CONTROL COMMANDS

engine status: id6 - sw

engine throttle: id1 – throttle

3.SPEED CONTROL MODE

engine status: id6 - sw

engine rpm: id7 – rpm

speed ratio: id6 – rpm_x (rpm_x non-zero, enter speed control mode)

*target speed = [id7:rpm] * [id6:rpm_x] * 10*

5.5 INSTRUCTIONS FOR CONNECTING ENGINES WITH DIFFERENT STARTING MODES

INSTRUCTIONS FOR CONNECTING AND STARTING THE ENGINE CONTROLLED BY A REMOTE CONTROL(REMOTE CONTROL AND RECEIVER PRODUCTS NEED TO BE PREPARED BY ONESELF)

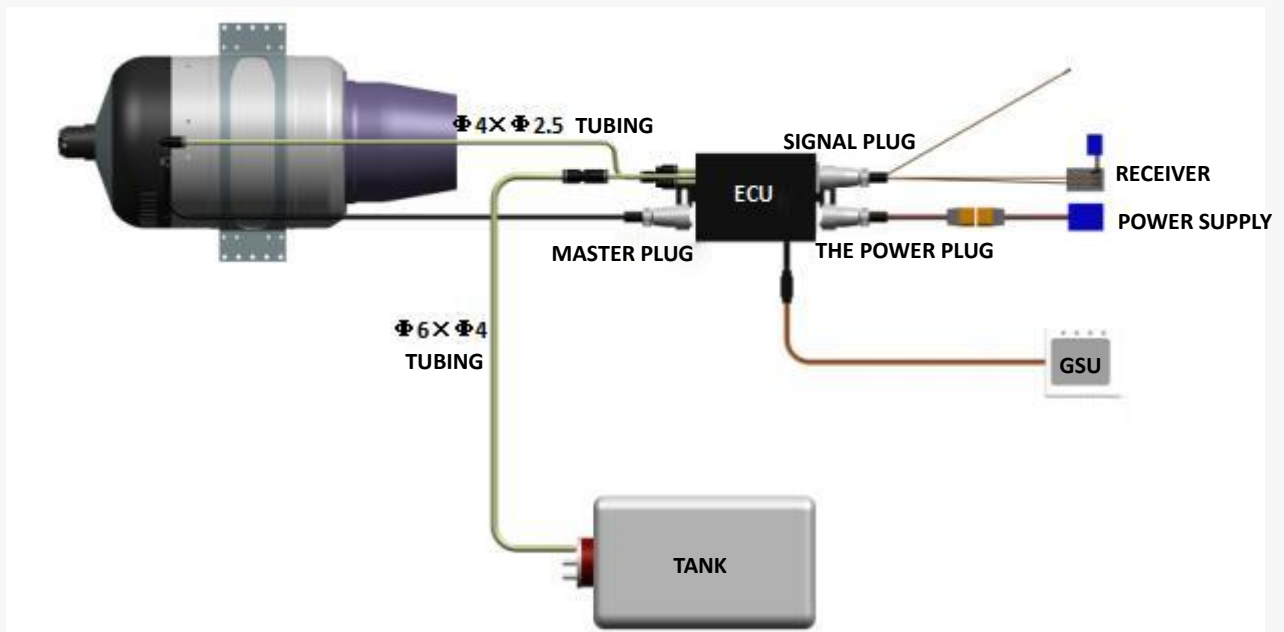

explain:

the engine is firmly fixed and connected to the engine, ecu, and oil circuit according to the diagram. note that the plug labeled "rs232" on the signal line is not needed. the other two plugs are connected to the receiver switch channel through the "switch" and the receiver throttle channel through the "throttle".

after all wire harness connections are completed, the ecu emits a "drip drip drip drip" music prompt, indicating that the connections are intact. after the engine is connected, the ecu will

intermittently emit a "beep" prompt sound without any commands.

1. before connecting the engine, determine the power supply voltage. the sw300pro-k and sw400pro-k use 16.8-24v batteries. pay attention to the remote control receiver battery meeting the requirements (generally choose 2s battery), excessive voltage can burn out the receiver.

2. complete the frequency matching between the remote control and the receiver according to the instructions for using the remote control.

3. use the monitor (gsu) to calibrate the remote control and engine throttle. the calibration method can be found on page 20.

after calibration is completed, use the gsu testing function to test the main fuel pump. press and hold the "test main fuel pump" button until the fuel line is filled with fuel. pay attention to stopping the fuel pump immediately when the fuel level enters the engine to prevent a large fire from spraying when the engine starts with rich fuel inside.

4. the engine starting process is divided into four stages: ignition, preheating, acceleration, and operation, which can be observed through the display during ground testing. before stopping the engine, first reduce the speed to idle, then adjust the remote control throttle lock to the cooling mode, and the engine will automatically cool down. the engine can be restarted in both cooling and shutdown states.

Instructions for connecting and starting the engine controlled by RS232/RS422 serial port tool

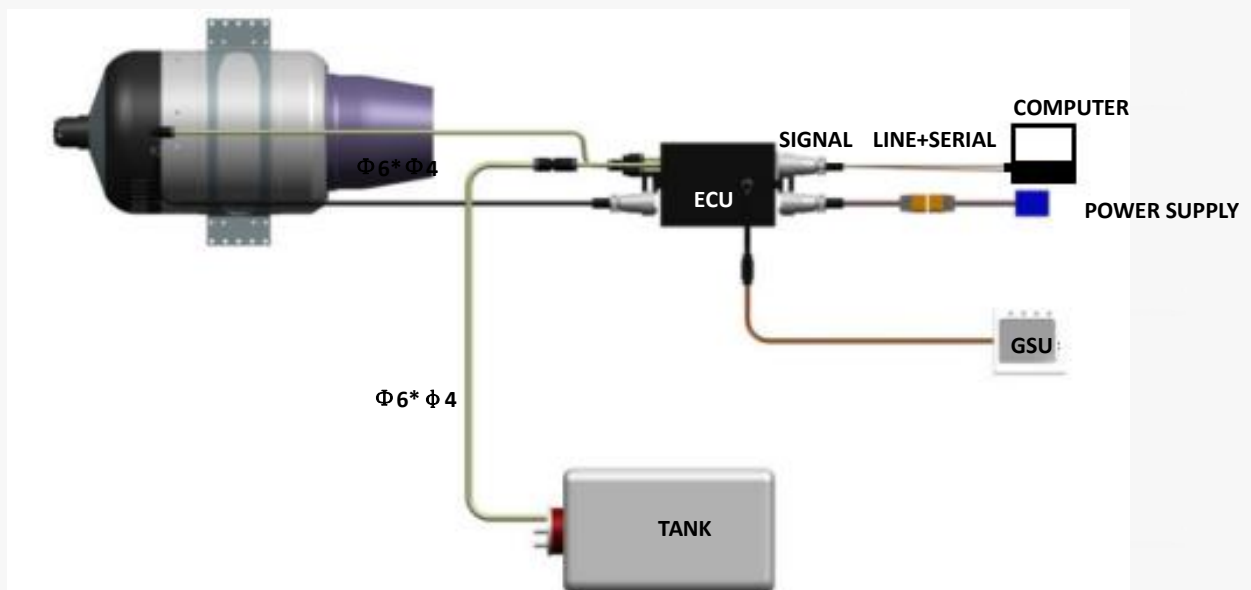

instructions: connect the engine, ecu, and oil circuit according to the diagram above.

1. connect the signal line rs232 and 232 serial port tools with the dupont connector, paying attention to aligning the brown wires of the two plugs in the direction of insertion. if you need other interface definitions, you can contact swiwin after-sales to customize the wiring harness.

2. it is recommended to choose zk software to control the engine. the software can be obtained for free by contacting swiwin after-sales service.

3. the above operation is normal, and the zk software interface displays the engine parameters, indicating normal feedback.

first, use the testing function to test the main oil pump and exhaust the air inside the oil pipe. pay attention to the fuel level entering the engine and immediately stop pumping oil to prevent the engine from spraying large flames when starting with rich fuel inside.

3. the engine starting process is divided into four stages: ignition, preheating, acceleration, and operation, which can be observed through the display during ground testing. before stopping the engine, reduce the speed to idle first, and then click "stop cooling" to automatically cool down the engine. the engine can be restarted in both cooling and shutdown states.

INSTRUCTIONS FOR CONNECTING AND STARTING THE ENGINE USING FLIGHT CONTROL

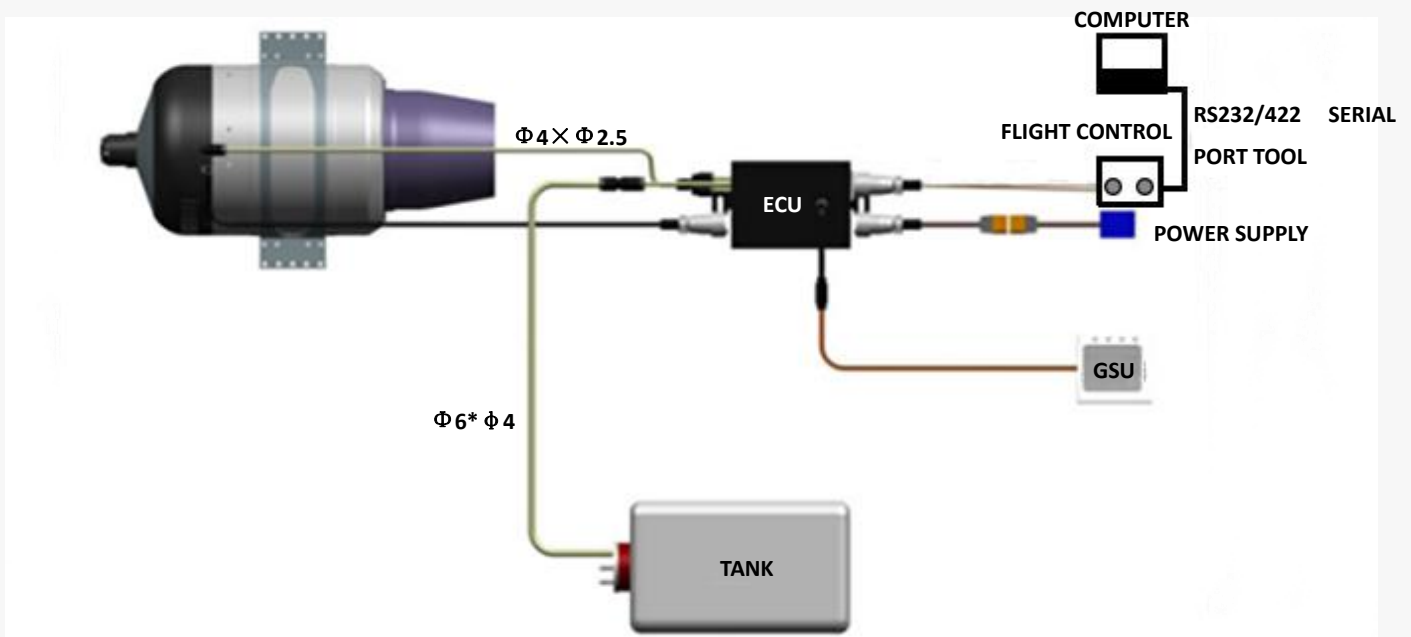

instructions: connect the engine, ecu, and oil circuit according to the diagram above.

- 1. connect the rs232 signal cable to the flight control signal plug. if you need other interface definitions, you can contact swiwin after-sales to customize the wiring harness.*
- 2. the above operation is normal, and the flight control software interface on the computer displays the engine parameters, indicating normal feedback.*
- 3. first, use the testing function to test the main oil pump and exhaust the air inside the oil pipe. pay attention to the fuel level entering the engine and immediately stop pumping oil to prevent the engine from spraying large flames when starting with rich fuel inside.*
- 4. the engine starting process is divided into four stages: ignition, preheating, acceleration, and operation, which can be observed through the display during ground testing. before stopping the engine, reduce the speed to idle first, and then click "stop cooling" to automatically cool down the engine. the engine can be restarted in both cooling and shutdown states.*

5.6 ONE CLICK START

ECU V4 VERSION SUBMISSION 2.1.16 OR ABOVE;

GSU SUBMISSION ABOVE 1.3.26

- 1. press and hold the gsu "+" and "-" keys simultaneously for 3 seconds, then select "start engine" on the gsu display and choose to start.*
- ① after sending the startup command, if there is no startup within 3 seconds, the control will automatically exit;*
- ② after entering the startup mode, the gsu "+" and "-" keys can be used to control the engine speed, with "10%" in gear 1, for throttle control;*
- ③ after entering the startup mode, press the "c" key to immediately stop and cool down;*
- ④ after entering the startup mode, the throttle progress bar flashes continuously.*

5.7 GSU USER MANUAL

gsu is a terminal for displaying and editing engine parameters, which can be connected or disconnected from the engine at any time. even during engine operation, you can adjust some engine parameters through gsu.

CONNECTION OF GSU

the gsu is connected to the engine through the ecu, and its connection interface is a dupont head, which is connected to the data cable interface on the ecu. when connecting, please pay attention to the yellow lines corresponding to the two dupont heads. after connection, the gsu displays the following interface to indicate successful connection.

GSU

the default language for gsu factory settings is simplified chinese. if you need to modify it, select "language" in the settings interface. there are 4 options: english, simplified chinese, traditional chinese, and spanish.



INSTRUCTIONS

click "ok" on the initial interface to enter the settings interface. the first time using the engine, the main functions are "calibration remote control" and "testing". the other parameters have already been debugged to the best state when they are sent out, please do not change them arbitrarily.



METHODS FOR TESTING ENGINES

before starting the engine, use the gsu testing function to confirm whether all hardware is working properly. the testing method is to select the test item and click the "ok" button. during the test, the solenoid valve made a clicking sound, and the motor started to drive the impeller to rotate normally. finally, when testing the fuel pump, it can be observed that the fuel level is flowing towards the interior of the engine, indicating that the fuel pump is working properly.



METHOD OF CALIBRATING REMOTE CONTROL

confirm that the throttle lock on the remote control is open before calibration. select the calibration remote control on the monitor to enter the following interface.

click on 'max', push the throttle lever to the maximum, and click 'ok' to complete 100% throttle calibration.

click "idle", push the throttle lever to the minimum, and click "ok" to complete the idle calibration.

turn off the throttle lock, click "min", push the throttle lever to the minimum, and click "ok" to complete the shutdown state calibration.

after completing the above operations, the gsu returns to the initial interface, pushes the throttle control lever, and observes the rc value changing with the throttle, indicating that the remote calibration is successful.

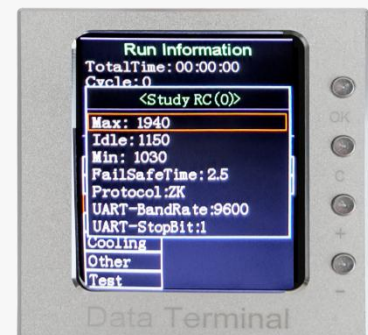

STARTUP SETTINGS

pump voltage: control the starting oil output, the higher the voltage, the more oil is supplied.

rpm startup ramp: it refers to a time period from ignition to clutch disengagement, during which the slope of the starter motor speed increases. the higher the slope, the faster the speed increase.

pump startup ramp: it refers to the fuel supply slope of the oil pump during the engine start-up phase. the higher the slope value, the greater the

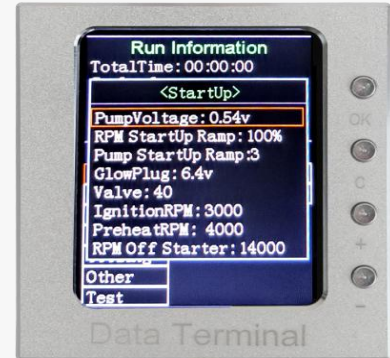

MAIN INTERFACE

The engine operation interface consists of three parts: the top part shows the parameters of the previous engine operation. The middle section displays the engine operating status, with green font for normal status and red font for abnormal error messages. The bottom section displays real-time data on engine rpm, temp, pump, rc.



in addition to the above instructions, if you need to set other parameters, you can contact swiwin after-sales service to help you solve the problem.

TEMPERATURE CORRECTION

during the engine start-up process, the ecu controls the engine operation by judging the built-in temperature sensor. if the temperature sensor inside the engine differs significantly from the ambient temperature, it will affect the ecu's judgment and require the use of gsu for temperature calibration of the engine.

on the gsu main interface,select"other"



select 'ad just temp' and click '+'-' to adjust the temperature up and down, keeping the corrected temperature consistent with the ambient temperature.



5.8 ECU (V4) INSTRUCTIONS

hardware preparation: the following hardware is required for downloading ecu data or changing settings and parameters

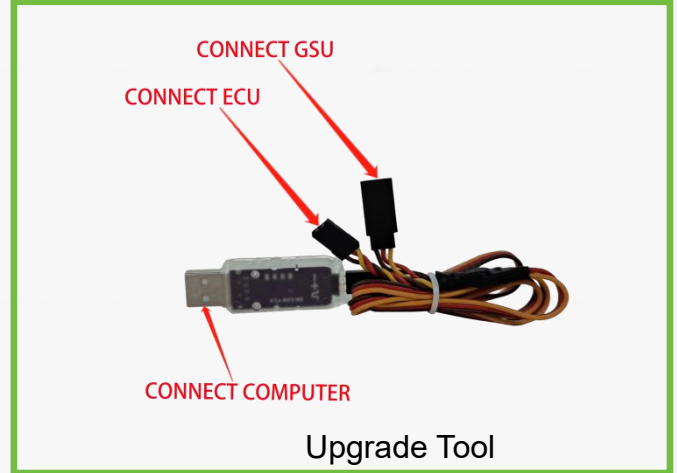

connect

connect as shown in the diagram below, the ecu is connected to the computer through an upgrade cable

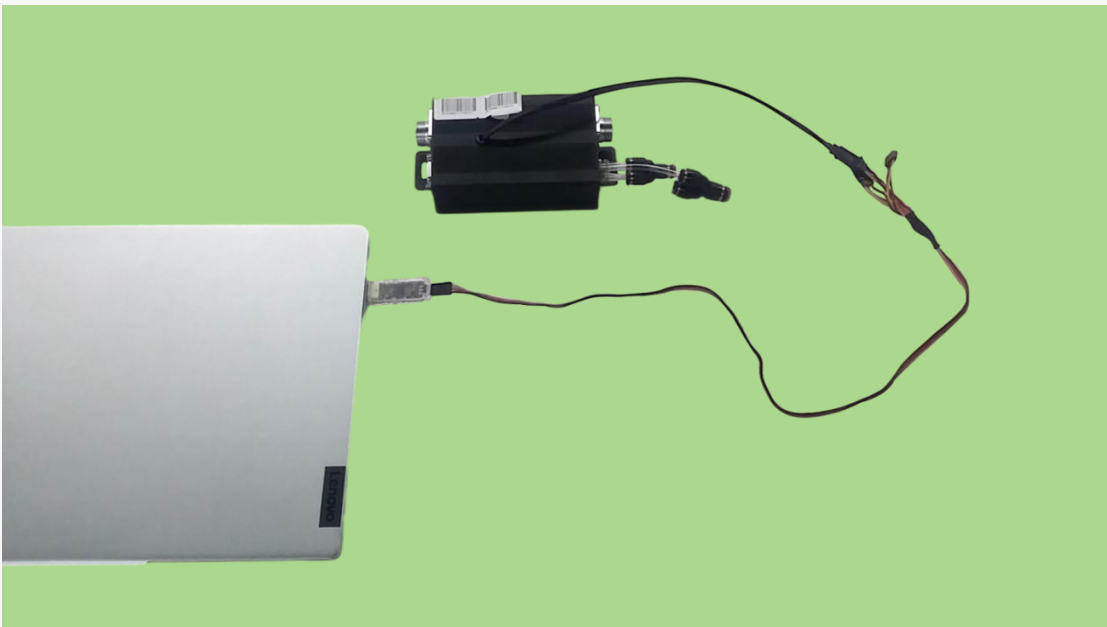

SOFTWARE UPGRADE

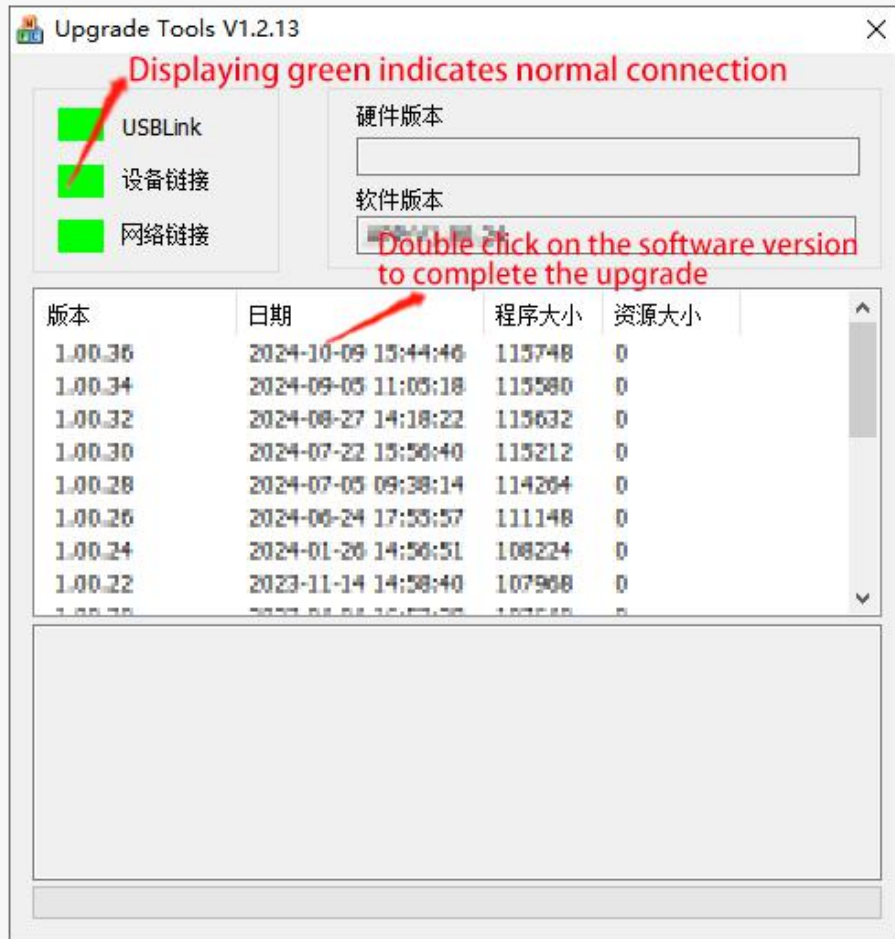

1. after the hardware is ready, log in to the swiwin website <http://www.swiwin.com> download upgrade tools.

2. open upgrade tools to upgrade the software, double-click to select the corresponding software version, and wait for the upgrade to complete.

DATA DOWNLOAD

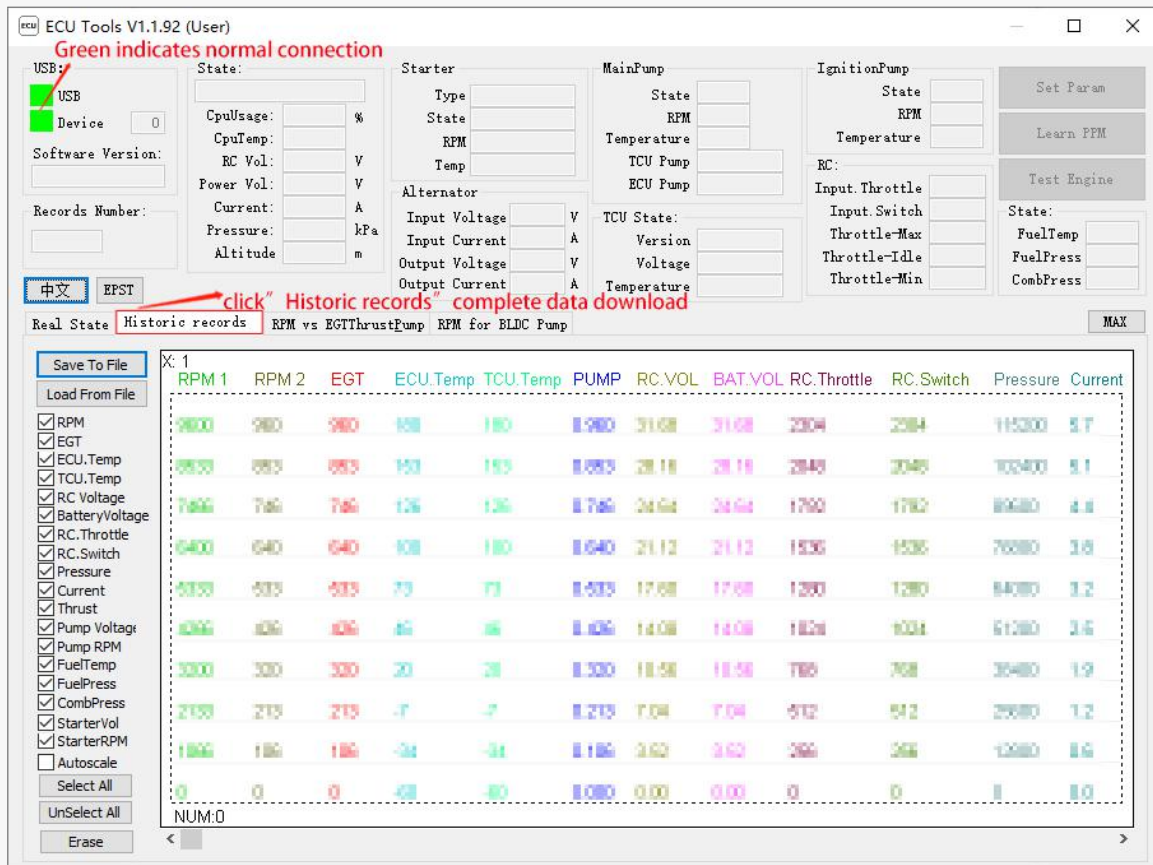

Green indicates normal connection

click "Historic records" complete data download

RPM 1	RPM 2	EGT	ECU.Temp	TCU.Temp	PUMP	RC.VOL	BAT.VOL	RC.Throttle	RC.Switch	Pressure	Current
980	980	980	108	180	1.980	31.08	31.08	2304	2384	115200	5.7
983	983	983	103	183	1.983	28.18	28.18	2848	3048	102400	5.1
786	786	786	136	136	1.786	34.64	34.64	1760	1782	89600	4.4
640	640	640	108	180	1.640	21.12	21.12	1836	1536	70880	3.8
533	533	533	73	73	1.533	17.68	17.68	1280	1280	64080	3.2
406	406	406	46	46	1.406	14.08	14.08	1824	1034	51280	3.6
300	300	300	20	28	1.300	18.58	18.58	788	768	38480	1.9
218	218	218	-7	-7	1.218	7.04	7.04	912	912	28880	1.2
186	186	186	-34	-34	1.186	3.62	3.62	366	366	12880	0.6
0	0	0	-68	-80	1.080	0.00	0.00	0	0	0	0.0

1. after the hardware is ready, log in to the swiwinwebsite <http://www.swiwin.com> download ecu tools (user) software.

2. open the ecu tools (user) software, click on "history" and wait for the data to load, then click on "save data" to complete.

MODIFY BAUD RATE/CHANGE SETTING PARAMETERS

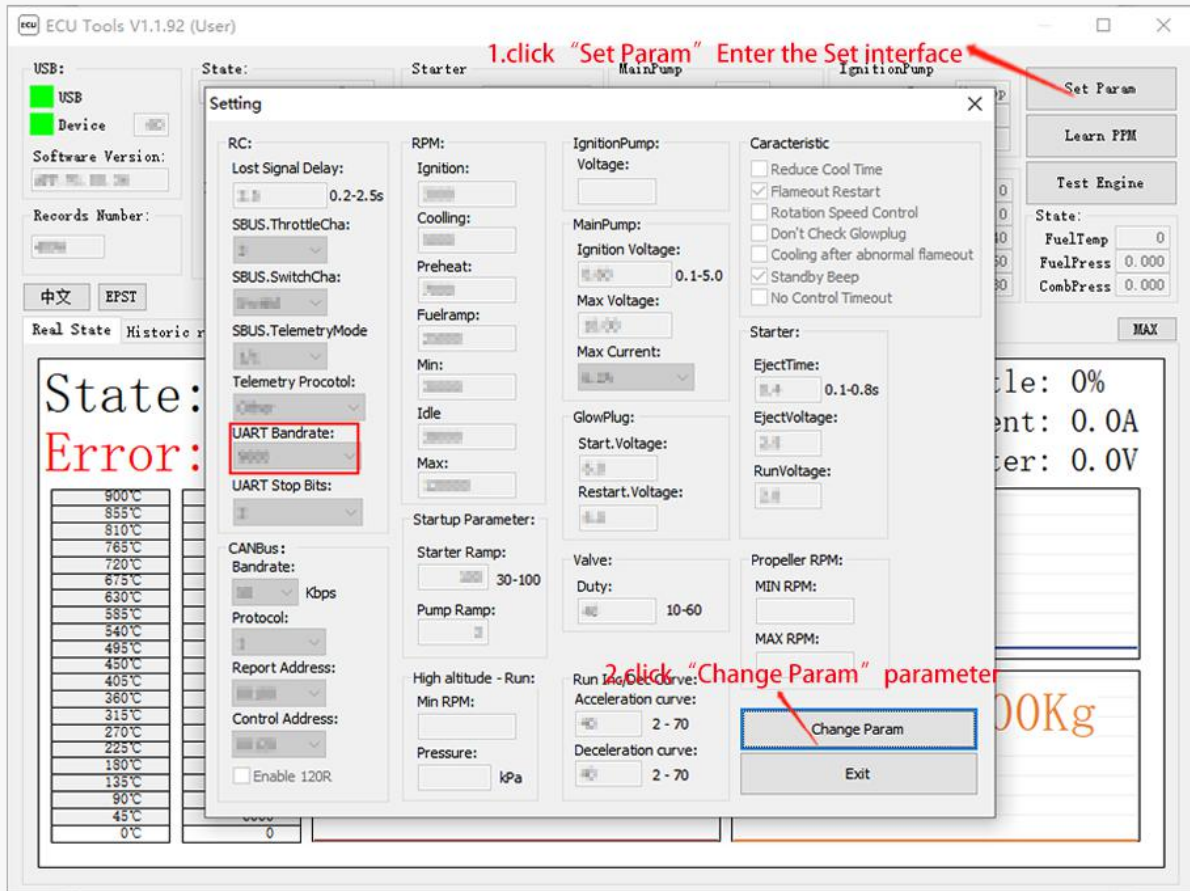

1. after the hardware is ready, log in to the swiwin website <http://www.swiwin.com> download ecu tools (user) software.

3. open the ecu tools (user) software, click "set parameters" to open the settings interface, and click "modify" to modify the settings and parameters.

CANCEL REMOTE CONTROL SIGNAL LOSS MONITORING

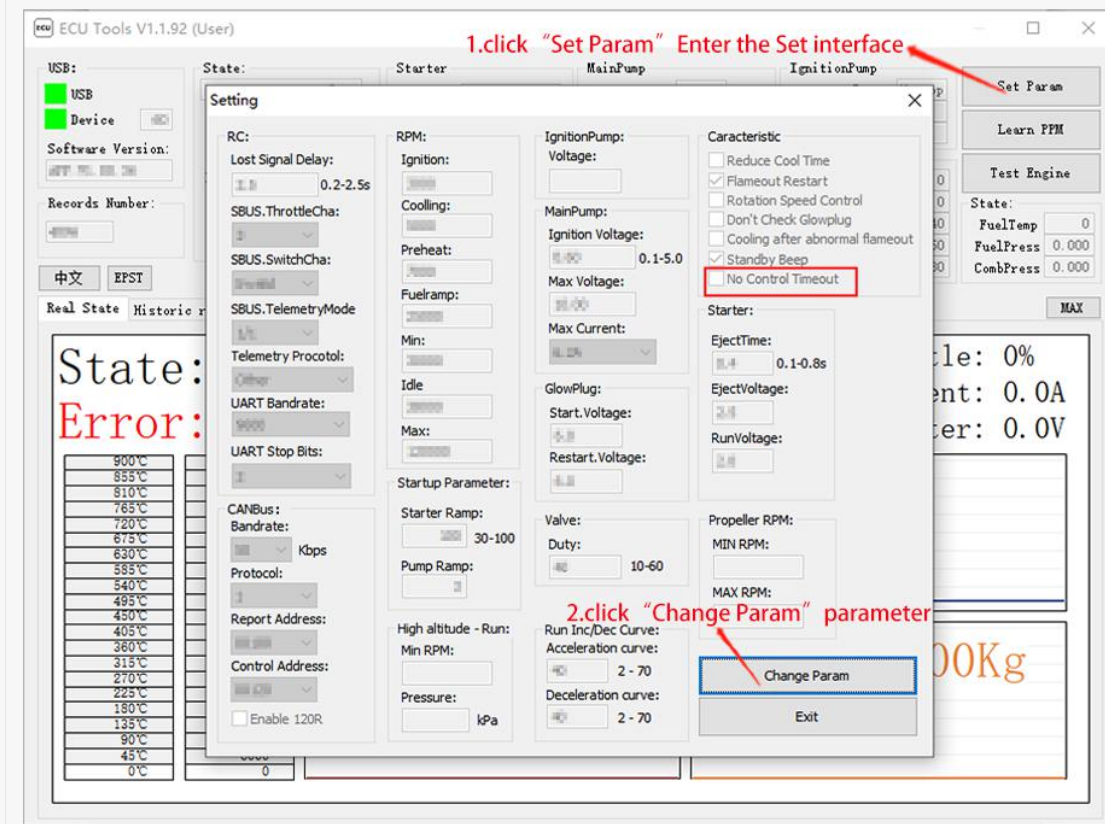

open the ecu tools (user) software, click on "set parameters", in the "characteristic parameters" column, check "cancel remote control signal loss monitoring". attention: after selecting "cancel remote control signal loss monitoring", the ecu will continue to execute the last command of the engine after receiving the signal interruption. if "cancel remote control signal loss monitoring" is not selected, the engine will stop directly after 2.5 seconds of signal interruption and immediately enter the cooling state.

you can also use the same method to change "acceleration cooling", "shutdown restart", "speed closed-loop control", etc.

note: at the factory, all parameters and characteristic parameters of the engine have been set according to the engine performance and customer requirements. please make sure to communicate with swiwin after-sales personnel before making any changes.

6. ENGINE DEBUGGING

6.1 SET OPERATION MODE

before running the engine for the first time, please check if the desired engine starting method has been set. you can prepare the necessary tools in advance based on the chart below.

STARTUP METHOD	REQUIRED SOFTWARE/HARDWARE	WIRE HARNESS CONNECTION
232/422 serial port startup	zk v0.1.32	the signal line+rs232/422 serial port tool
remote control	remote control, receiver	the signal line
flight control	flight control software	ecuto the flight control adapter cable

•choose the correct battery type

swiwin professional version engine power supply voltage requirements: 16.8-24v。

6.2 CHECKLIST

preparation before starting the engine

- check the battery voltage.*
- prepare at least one co2 fire extinguisher.*
- check the fuel pipeline to ensure that it is clean, unobstructed, and not bent. ensure that the fuel tank to ecu and ecu to engine section oil pipes are filled with fuel and there is no rich fuel inside the engine. ensure that the intake valve of the fuel tank is open. if there is no intake valve in the fuel tank or the intake valve is not open, it will cause the oil circuit to be blocked and the engine to fail to start.*
- confirm that 3% -5% lubricating oil is mixed in the fuel.*
- the fuel tank is full, and the fuel consumption of the professional version engine is 0.8-1.2l/min. the sufficient fuel level will be determined based on the flight time you have booked.*

•the wiring harnesses of the engine are connected correctly, the throttle calibration of the remote control is normal, and the data transmission from the handheld terminal/ground station is normal.

•the engine is firmly fixed, the surrounding environment is safe, and there are no debris near the engine intake.

6.3 ENGINE START AND STOP

the startup checklist has been checked and all wiring harnesses of the engine have been connected. the engine can now be started.

6.4 USE REMOTE CONTROL TO START AND STOP

•before starting, use the monitor (gsu) to calibrate the remote control and engine throttle. the calibration method can be found on page 21. after calibration is completed, use the gsu testing function to test the main fuel pump. press and hold the "test main fuel pump" button until the fuel line is filled with fuel. pay attention to stopping the pump immediately when the fuel level enters the engine to prevent the engine from becoming rich in fuel and spraying a large flame when starting. press and test the ignition solenoid valve and main solenoid valve. if you hear a "click click" sound, it indicates that the solenoid valve is functioning properly. test the starter motor (rotating the impeller clockwise) and the ignition head (using the gsu test function interface to detect current changes), and determine that all engine components are working properly before starting the test.

•before starting, the remote control throttle lever is in the minimum position, and the throttle adjustment is in the stop position. adjust the throttle to modulate the start gear, and the engine will start to ignite.

•the engine starting process is divided into several stages: preparation for starting, ignition, preheating, and acceleration. start successfully, engine speed reaches and maintains idle.

•after the engine reaches idle speed, the engine speed is controlled by adjusting the throttle through the throttle lever. 100% throttle corresponds to the maximum engine speed. note that the new machine should slowly accelerate to maximum speed and run steadily during its first operation, so that the ecu can learn the throttle.

●before the engine stops running, first adjust the throttle lever to the minimum. after the engine speed drops to idle, fine tune the throttle to the shutdown cooling gear, and the engine will automatically cool down and dissipate heat. during cooling, the starting motor of the engine will drive the compressor wheel at a lower constant speed until the exhaust temperature drops below 100 ℃, at which point the engine will shut down.

●when the turbojet engine is running, the suction at the intake port is like a vacuum state, and hands should never be placed near the intake port of the engine. keep a clear space around the intake port, fix the wires properly, and install protective nets. inhaling foreign objects into a turbojet engine can cause serious damage.

during the operation of a turbojet engine, a large amount of high-temperature hot air is generated, and the exhaust temperature can reach up to 750 degrees celsius. pay attention to the surrounding insulation and temperature prevention measures. it is absolutely forbidden to start indoors. turbojet engines consume a large amount of oxygen, causing suffocation of personnel. The emitted hot air and strong airflow pose a danger of igniting dry and flammable materials, and blowing away debris.

●when flying, the speed is fast, and absolute attention should be paid to the safety of the airspace and ground.

6.5 PC SIDE CONTROLS START AND STOP

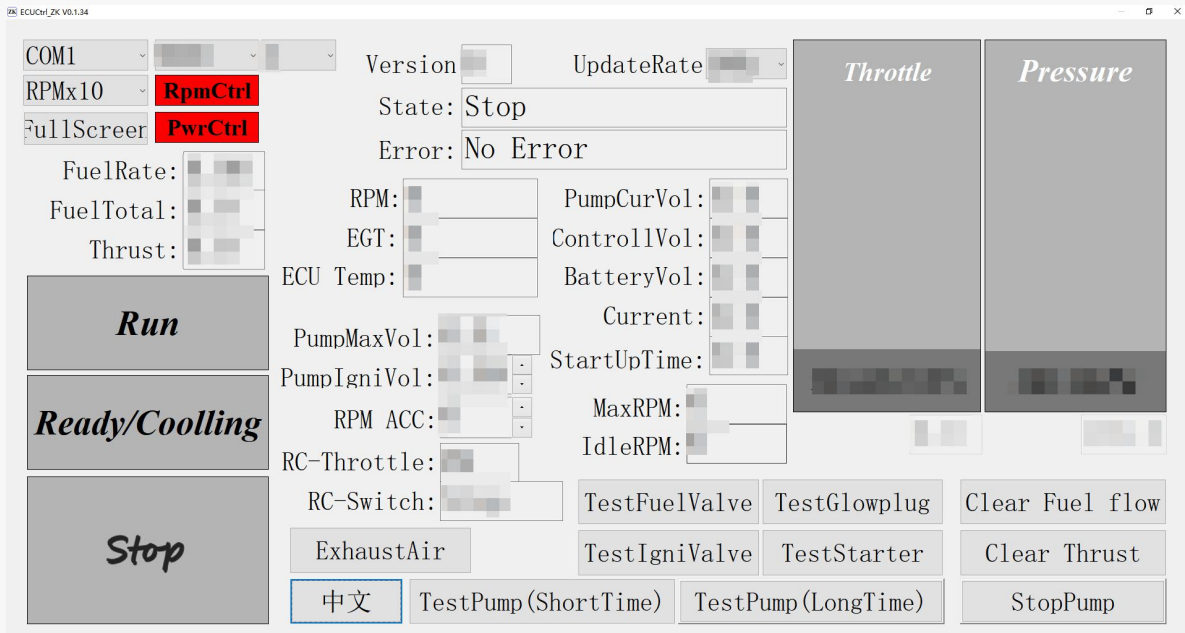

- Open the ZK software. Click on 'throttle control', and all power parameters on the ZK interface will return normally. Click 'start' to start. If there is no feedback on the ZK interface, click the button in the upper left corner of the page to select a different COM channel, baud rate, or check the compatibility between the serial port tool and the computer (refer to ZK software data feedback on page 32).
- after confirming the feedback, use the gsu testing function to test the main fuel pump. press and hold the "test main fuel pump" button until the fuel line is filled with fuel. pay attention to stopping the pump immediately when the fuel level enters the engine to prevent the engine from becoming rich in fuel and spraying a large fire when starting. press and test the ignition solenoid valve and main solenoid valve. if you hear a "click click" sound, it indicates that the solenoid valve is functioning properly. test the starter motor (rotating the impeller clockwise) and the ignition head (using the gsu test function interface to detect current changes), and determine that all engine components are working properly before starting the test.
- click "start" to start the engine. after reaching idle speed, control the engine speed through the throttle lever, and click "stop/cooling" to stop the engine.

7.ENGINE OPERATING STATUS

swiwin engine undergoes several different states from ignition to cooling, and the transitions of these states are automatically controlled by the ecu and user commands. all operating states of the engine will be displayed on the gsu.

ENGINE STATUS DESCRIPTION

DISPLAY NAME	EXPLAIN
stop	the remote control fine-tuning is in the off gear or the engine control software has not sent a start command to the ecu.
get ready to start	the engine ecu receives the start command, and the engine is ready to start. this stage is very short, and the display shows that the engine will immediately enter the ignition state after the start is ready.
ignition	when in ignition state, the engine spark plug is energized, the ignition solenoid valve opens, the engine completes ignition, and the starter motor drives the engine to reach ignition speed, causing the internal temperature of the engine to rise.
preheat	entering the preheating state, the starter motor continues to drive the engine speed to increase by 1000-2000 revolutions per minute, and the internal temperature of the engine continues to rise.
accelerate	entering the acceleration phase, the starter motor continues to drive the engine speed to increase to the clutch disengagement speed, the starter motor stops working, the internal temperature of the engine reaches above 100 °C, and ignition is successful.
function	after the acceleration phase is completed, the engine speed reaches idle, and thereafter, the engine speed needs to be controlled through the throttle, with 100% throttle corresponding to the maximum engine speed.
cooling	adjust the remote control to the shutdown cooling gear, and the engine starter motor drives the compressor wheel to run at a lower constant speed until the internal temperature of the engine drops below 100 °C, and then the engine stops.
engine not detected	the connection between the engine and ecu is disconnected.
engine model	the gsu operating interface displays the engine model within the white box below the swiwin logo.
time	indicates the total time the engine has been running this time
acc	indicates the time it takes for the engine to reach maximum speed from idle, which can be adjusted by changing the acceleration/deceleration curve.

speed	gsu operating interface, "rpm" represents the real-time engine speed during operation.
temperature	gsu operation interface, "temperature" represents the real-time internal temperature of the engine during operation.
oil pump power	on the gsu operation interface, "oil pump" represents the real-time oil pump power during engine operation.
remote control throttle	gsu operation interface, "remote control" represents the real-time throttle status during engine operation.

8. COMMON PROBLEM ELIMINATION

8.1 COMMON PROBLEM ELIMINATION

PROBLEM DESCRIPTION	CAUSE ANALYSIS	REMEDIAL MEASURES
engine ignition failure	the fuel pipe is not filled with fuel in advance, or the pipe is bent or blocked spark plug malfunction	fill the fuel pipe with fuel using the gsu testing function when using the gsu "test flame", there is no current displayed or no bright spot can be observed from the tail nozzle. in this case, contact swiwin after-sales service to return to the factory for repair
engine startup failure	low battery starting motor malfunction spark plug malfunction	battery charging depot repair depot repair
the throttle does not match the actual engine speed	remote control calibration not performed	re calibrate the remote control
The starting motor slips and produces abnormal noise	there is fuel on the contact surface between the compressor nut and the starter motor clutch rubber ring rubber ring wear	clean the rubber ring with a cotton swab dipped in alcohol or cleaning agent replace the rubber ring
engine ignition successful but startup process aborted	there are bubbles in the fuel supply pipe the oil pump is not working	oil circuit leakage, check all quick connectors

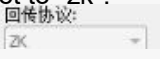
<p>unstable exhaust temperature or engine speed</p>	<p>remote control antenna signal is interfered with</p>	<p>identify sources of interference</p>
<p>zk software does not have data feedback</p>	<p>the power is not turned on</p> <p>signal line connection not in place/incorrect connection</p> <p>the computer does not have drivers installed</p> <p>the signal channel does not match the actual situation</p> <p>inconsistent return protocol</p>	<p>turn on the power</p> <p>check if all plugs and wiring harnesses are connected properly, if the serial port tool and signal line 232 are connected correctly, and if the serial port is plugged into the computer's usb port</p> <p>contact swiwin after-sales service to obtain or install driver sprites and drivers for life on your computer. download and install drivers in an online environment</p> <p>unplug the usb plug from the computer, check the device manager, open the zk software in the upper left corner, and select the corresponding signal channel. (usually, computer device managers will display numbers such as com3, com3, or com7)</p> <p>open the ecu tools software, open the settings parameter, and check if the feedback protocol setting is set to "zk".</p> 

8.2 ECU ERROR FAULT ANALYSIS

during the operation of the engine, if there is a signal malfunction, the ecu will automatically report an error. the following table explains these faults.

ERROR NAME	EXPLAIN
overtime	during ignition: temperature remains unchanged for 20 seconds forced cooling: time exceeding 60 seconds
low battery voltage	the voltage of the power battery is lower than the minimum value (the minimum value can be modified) the voltage of the remote control receiver is below 4v
fire head malfunction	no flame current detected
abnormal oil pump	unable to connect to the oil pump motor controller (only supported on brushless motor version)
starting motor malfunction	during ignition: the engine speed cannot reach the ignition speed
low rotational speed	when igniting: the engine speed drops to 50% of the ignition speed during preheating: the engine speed drops below the ignition speed during acceleration: the engine speed drops below the warm-up speed during operation: the engine speed is lower than the set minimum speed
unstable rotational speed	during acceleration: engine rpm fluctuates up and down during acceleration: the engine speed drops significantly
high temperature	during ignition: the exhaust temperature is greater than the set maximum temperature value during preheating: the exhaust temperature is higher than the set maximum temperature value during acceleration: the exhaust temperature is greater than the set maximum temperature value for 4 seconds
low temperature	during preheating, there is a significant decrease in exhaust temperature during acceleration, there is a significant decrease in exhaust temperature
temperature sensor malfunction	during operation: exhaust temperature below 200 degrees celsius
lost remote control signal	remote control input signal lost, time exceeds set value
high starting motor temperature	the temperature of the starter motor controller is too high (only supported in the brushless motor version)
high oil pump temperature	the temperature of the oil pump motor controller is too high (only supported in the brushless motor version)
current overload	the working current of the ecu exceeds the design limit, and the current limit

	of different versions of the ecu varies
engine offline	ecu did not detect engine connection (only supported by bus controller version)

9. COMPATIBILITY

if using zk or flight control software to control the engine, the connection between the engine and your device involves compatibility issues.

9.1 COMPATIBILITY OF SERIAL PORT ADAPTER CABLE CONNECTORS

NAME	PERFORMANCE INDEX	COMPATIBILITY
RS232 ADAPTER YHL-B232	USB2.0,COMPATIBLE USB1.1 SUPPORT RS232 THREE WIRE SERIAL PORT INTERFACE USB BUS FOR DIRECT POWER SUPPLY WITHOUT THE NEED FOR AN EXTERNAL POWER SOURCE EQUIPPED WITH A SET OF 5V/500MA POWER OUTPUTS	SUPPORT COMPUTER SYSTEMS : WINDOWS2000、WINDOWSXP、WINDOWS SERVER 2003 (32、64 位)/VISTA/WINDOWS 7 (32、64 位)、WINDOWS 8、WINDOWS10

9.2 UPGRADER COMPATIBILITY

NAME	PERFORMANCE INDEX	COMPATIBILITY
UPGRADER (ZK-LINK V1.4)	-----	SUPPORT COMPUTER SYSTEMS : WINDOWS7、WINDOWS 8、WINDOWS10

10. STORAGE AND LUBRICATION

all models of engines from swiwin company can use kerosene or diesel as fuel, and are mixed with 3% -5% lubricating oil. this mixed lubricating oil is also used in the bearing lubrication system, and it is recommended to use swiwin brand or mobil pegasus no.2 lubricating oil.

the engine has been stored for more than 3 months. to prevent bearing corrosion, it is recommended to lubricate the engine thoroughly with fuel, place it vertically, and seal it with a sealed bag. if there are ground testing conditions, ignition testing can provide better maintenance for the engine. if necessary, you can also contact after-sales personnel to return to the factory for maintenance.

11. ENGINE MAINTENANCE AND UPKEEP

the maintenance requirements and cycle of the product, including cleaning, replacement of parts, etc.

1. maintenance plan: regularly inspect and replace lubricating oil, air filters, and other components of the engine.

2. daily maintenance: regularly check the fastening of various connecting parts and pipelines of the engine, and clean the surface of the engine.

3. troubleshooting: if encountering problems such as decreased engine performance or abnormal noise, follow the maintenance manual and troubleshooting process for operation.

to ensure stable and reliable operation of the engine, regularly check the following during use:

- is there any burning or discoloration on the engine casing.*
- is the engine mount intact.*
- is the air inlet and impeller intact.*
- is there any leakage in the oil system and is the oil filter clogged.*
- bearing: manually rotate the rotor and carefully distinguish the bearing sound. if there is a "rustling" sound, the bearing may be slightly damaged due to impurities or improper cooling. it is recommended to use clean fuel or replace the oil filter. if the bearings are clearly*

damaged after inspection, it is prohibited to use the engine again. you can log in to the swiwin official website and contact after-sales personnel to replace the bearings.

*maintenance cycle: the regular maintenance cycle for pro-k series engine is: **25 hours per accumulated operating time.***

12. AFTER SALES SERVICE

limited liability warranty

the service life of a turbojet engine is directly related to the operating environment and operating techniques. the turbojet engine uses the simplest structure to achieve the most extreme working state, and each component is designed and produced to the extreme. the working conditions are extremely harsh. do not disassemble the intake duct and main shaft structure by yourself. once the turbojet engine is disassembled, it must be precisely reinstalled according to specifications to achieve its original performance. random assembly will cause the turbojet body to lose balance, and high-speed operation will cause serious consequences.

buyers of new swiwin engines are entitled to a one-year or 25 hour natural damage warranty. if you encounter any questions or operational issues during use, please contact the sales department.

if you need the engine to be returned to the factory for maintenance and repair, please log in to the official website of swiwin company <http://www.swiwin.com> or "swiwin power" official account to contact customer service, fill in the engine maintenance application form, and prepare the following relevant contents:

ENGINE MAINTENANCE APPLICATION FORM			
NAME		THE DATE OF ISSUANCE	
Shipping Address			
Fault Description	_____ Model:		
Other Service Requirements	<input type="checkbox"/> Technical Consultation <input type="checkbox"/> Engine Maintenance <input type="checkbox"/> Accessories Procurement		

SWIWIN TURBOJET EQUIPMENT CO.,LTD

Tel: 15531598038

Email: swiwin@foxmail.com

Web: <http://www.swiwin.com>

Add: 66 Jianye East Road, High-tech district,
Baoding, Hebei, China

